

# INSTALLATION AND MAINTENANCE INSTRUCTIONS

## **RPHP/RHP and RPCE/RCE Series**

### Self-Contained Heat Pump and Air Conditioner

*Save these instructions for future reference*

#### **WARNING**

Improper installation, adjustment, alteration, service, or maintenance can cause injury or property damage. Refer to this manual. For assistance or additional information, consult a qualified installer or service agency.

#### **WARNING**

Installation and servicing of air conditioning equipment can be hazardous due to internal refrigerant pressure and live electrical components. Only trained and qualified service personnel should install or service this equipment. Installation and service performed by unqualified persons can result in property damage, personal injury, or death.

#### **WARNING**

If this unit is to be installed in a mobile or manufactured home application, the ductwork must be sized to achieve static pressures within the manufacturer's guidelines. All other installation guidelines must also be followed. Failure to do so may result in equipment damage, personal injury, and improper performance of the unit.

#### **WARNING**

For your safety, do not store or use gasoline or other flammable vapors and liquids in the vicinity of this or any other appliance. Such actions could result in property damage, personal injury, or death.

#### **CAUTION**

The installation of this appliance must conform to the requirements of the National Fire Protection Association; the National Electrical Code, ANSI/NFPA No. 70 (latest edition) in the United States; the Canadian Electrical Code Part 1, CSA 22.1 (latest edition) in Canada; and any state or provincial laws or local ordinances. Local authorities having jurisdiction should be consulted before installation is made. Such applicable regulations or requirements take precedence over the general instructions in this manual.

#### **TABLE OF CONTENTS**

INSTALLATION .....	2
OPERATION .....	9
MAINTENANCE .....	10
WIRING DIAGRAMS .....	11
WARRANTY .....	16

Manufactured By  
**Allied Air Enterprises, Inc.**  
**A Lennox International Company**  
215 Metropolitan Drive  
West Columbia, SC 29170



## INSTALLATION

These instructions explain the recommended method of installation of the heat pump and air conditioner units and associated electrical wiring.

This unit is designed and approved for use as a self-contained air-to-air outdoor heat pump and air conditioner system.

The units are factory equipped with a transformer and blower control for applications without auxiliary heat. Electric heat accessory kits (AHSA-) can be ordered for field installation of additional heat where required.

These instructions, and any instructions packaged with mating components and/or accessories, should be carefully read prior to beginning installation. Note particularly any **CAUTIONS** or **WARNINGS** in these instructions and all labels on the units.

These instructions are intended as a general guide only, for use by qualified personnel and do not supersede any national or local codes in any way. Compliance with all local, state, provincial, or national codes pertaining to this type of equipment should be determined prior to installation.

### Inspection of Shipment

Upon receipt of equipment, carefully inspect it for possible shipping damage. If damage is found, it should be noted on the carrier's freight bill. Take special care to examine the unit inside the carton if the carton is damaged. File a claim with the transportation company.

If any damages are discovered and reported to the carrier **DO NOT INSTALL THE UNIT, as claim may be denied.**

**Check the unit rating plate to confirm specifications are as ordered.**

### Limitations

The unit should be installed in accordance with all national and local safety codes.

Limitations of the unit and appropriate accessories must also be observed.

The unit must not be installed with any ductwork in the outdoor air stream. The outdoor fan is not designed to operate against any additional static pressure.

Minimum and maximum operation conditions must be observed to assure maximum system performance with minimum service required. Refer to Table 1 for the application limitations of the unit.

### Location

The unit is designed to be located outdoors with sufficient clearance for free entrance to the air inlet and discharge air openings. The location must also allow for adequate service access. Figure 1 shows a typical installation.

The unit must be installed on a solid foundation that will not settle or shift. Adequate structural support must be provided. Maintain minimum clearances as shown in Figure 1 and Table 1 and install the unit in level position. Isolate the base from the building structure to avoid possible transmission of sound or vibration into the conditioned space.

**The heat pump unit foundation should be raised to a minimum of 3" above finish grade.** In areas which have prolonged periods of temperature below freezing and snowfall, the heat pump unit should be elevated above the average snow line. Extra precaution should be taken to allow free drainage of condensate from defrost cycles to prevent ice accumulation. The unit should not be located near walkways to prevent possible icing of surface from defrost condensate.

**Avoid placing the unit near quiet areas such as sleeping quarters or study rooms.** Normal operating sound levels may be objectionable if the unit is placed near certain rooms.

**Do not permit overhanging structures or shrubs to obstruct condenser air discharge inlet or outlet.**

**For improved start-up performance, the indoor coil should be washed with suitable detergent to remove any residue from manufacturing processes.**

### Roof Curb Installation

If a roof curb is used, follow the manufacturer's Installation Instructions and be sure that all required clearances are observed (see Clearances on page 3).

These units are shipped with four corner brackets in place on the underside of the unit (see Figure 2). **For heat pumps the two rear corner brackets must be removed before unit is installed onto roof curb assembly. For air conditioner units remove all four corner brackets before installing on roof curb.**

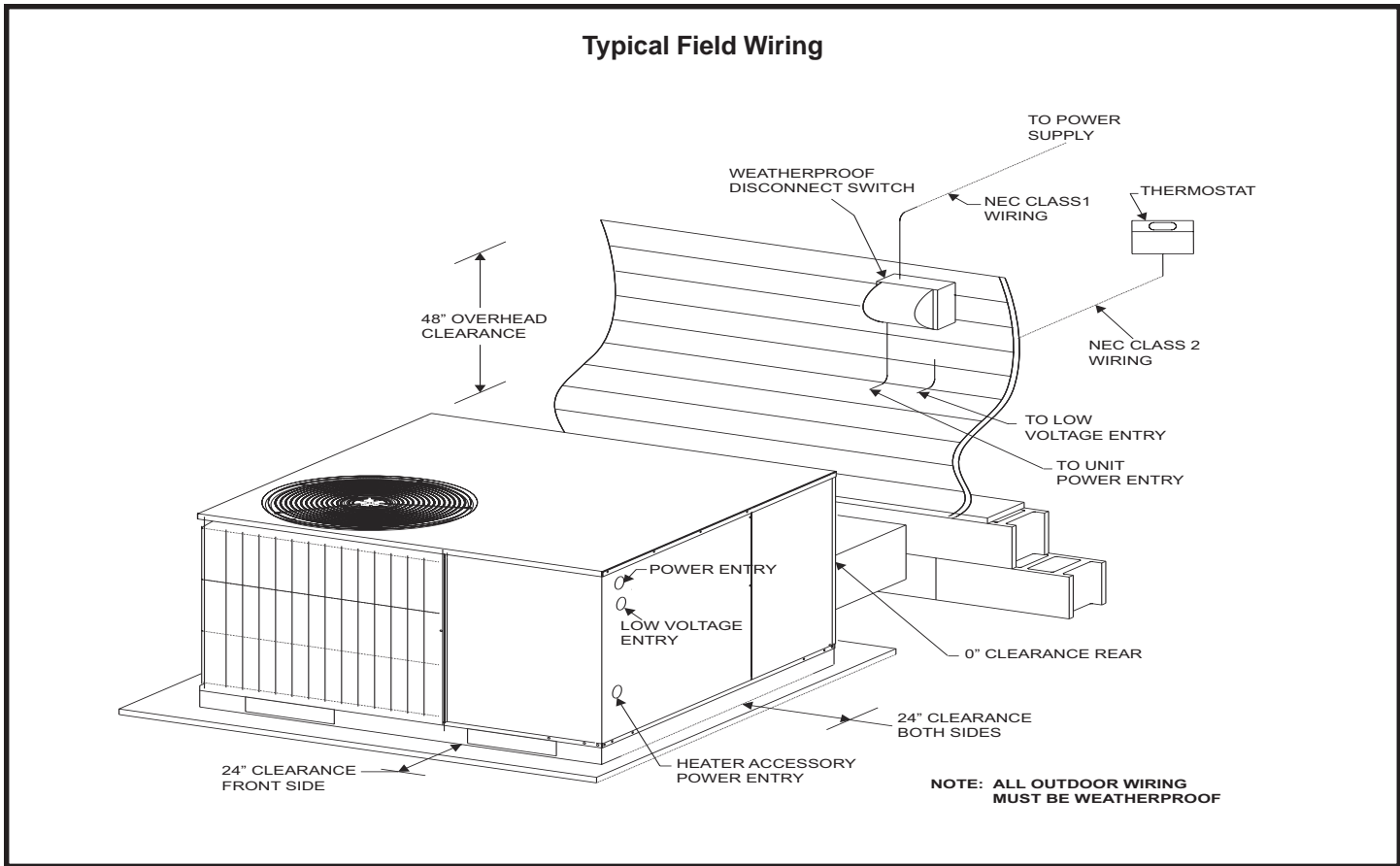

**Figure 1**

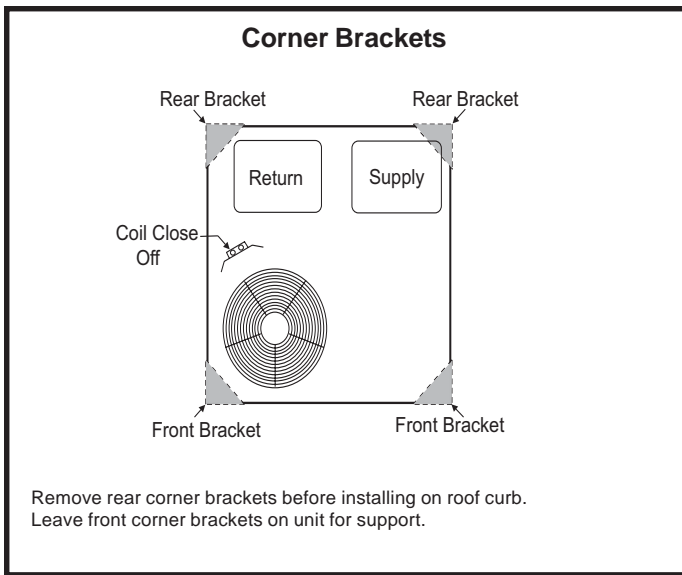

**Figure 2**

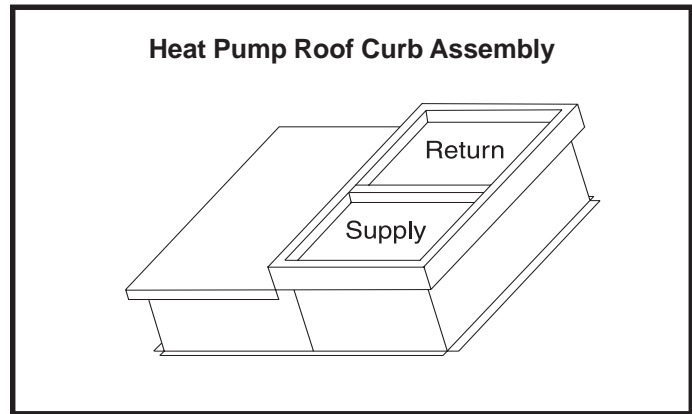

**Figure 3**

**Clearances**

All units require certain clearances for proper operation and service. Refer to Table 1 on page 4 for the minimum clearances to combustibles required for construction, servicing, and proper unit operation.

In the U.S., units may be installed on combustible floors made from wood or class A, B, or C roof covering material.

In Canada, units may be installed on combustible floors. Units must be installed outdoors.

Minimum Clearances		
	Combustibles	Service
Front of Unit	0	24"
Back of Unit	0	0
Left Side	0	24"
Right Side (Condenser Coil)	0	24"
Below Unit	0	0

Table 1

### Rigging and Handling

#### CAUTION

Before lifting a unit, make sure that the weight is distributed equally on the cables so that it will lift evenly.

Exercise care when moving the unit. Do not remove any packaging until the unit is near the place of installation. An accessory lift kit can be purchased to aid in rigging. Spreaders whose length exceeds the largest dimension across the unit **must be used across the top of the unit.**

Units may also be moved or lifted with a forklift while still in the factory-supplied packaging. **The lengths of the forks of the forklift must be a minimum of 42".**

### Compressor

Units are shipped with compressor mountings factory adjusted and ready for operation. **Do not loosen compressor mounting bolts.**

### Electrical Wiring

All field wiring must be done in accordance with National Electrical Code recommendations, local codes, and applicable requirements of UL, or in accordance with Canadian Electrical Code recommendations, local codes, or CSA Standards. Power wiring, disconnect means, and over-current protection are to be supplied by the installer. Refer to the unit rating plate for maximum over-current protection and minimum circuit ampacity, as well as operating voltage. The power supply must be sized and protected according to specifications supplied.

The unit must be grounded with a separate ground conductor. See Figure 4 for typical field wiring connection. The wiring diagram can be found on the unit inside the access panel. Low voltage control wiring are pigtail leads located on the main control box and are color-coded to match the connection called out on the wiring schematic.

#### CAUTION

When connecting electrical power and control wiring to the unit, waterproof-type connectors must be used so that water or moisture cannot be drawn into the unit during normal operation.

**Units are factory wired for a 230-volt power supply. If power supply is 208 volts, it will be necessary to change a wire connection on the unit transformer from 240V terminal to 208V terminal as shown on the wiring diagram.**

*Use only copper conductors.*

If any of the original unit wiring is replaced, the same size and type wire must be used.

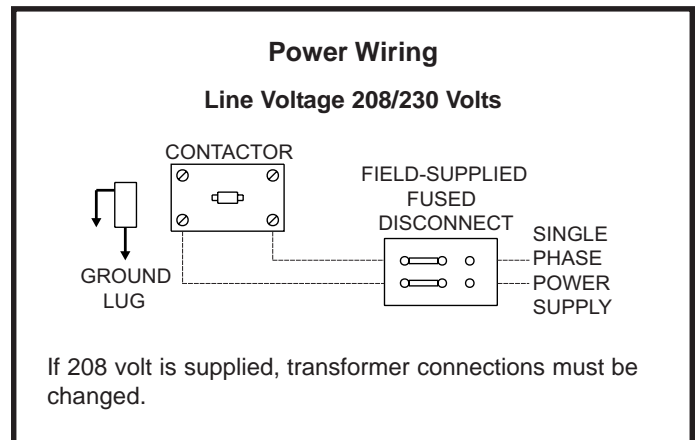

Figure 4

### Thermostat

The room thermostat should be located on an inside wall where it will not be subject to drafts, sun exposure, or heat from electrical fixtures or appliances. Follow the manufacturer's instructions enclosed with the thermostat for general installation procedure. Color-coded insulated wires (#18 AWG) should be used to connect the thermostat to the unit. A minimum of five wires are required for proper installation.

### Ductwork

Ductwork should be designed and sized according to the methods in Manual Q of the Air Conditioning Contractors of America (ACCA).

A closed return duct system shall be used. This shall not preclude use of economizers or outdoor fresh air intake. It is recommended that supply and return duct connections at the unit be made with flexible joints.

The supply and return air duct systems should be designed for the CFM and static requirements of the job. **They should not be sized to match the dimensions of the duct connections on the unit.**

### CAUTION

When fastening ductwork to side duct flanges on unit, insert screws through duct flanges only. Do not insert screws through casing. Outdoor ductwork must be insulated and waterproofed.

### Filters

Filters are not supplied with the unit. Filters must always be installed on the upstream side of the evaporator coil and must be kept clean or replaced. Dirty filters will reduce the airflow of the unit. Filters should be sized in accordance with Table 2 on page 6.

This unit is equipped with an internal filter clip which is located in the indoor coil compartment attached to the side of the unit drain pan.

### Typical Wiring Connections

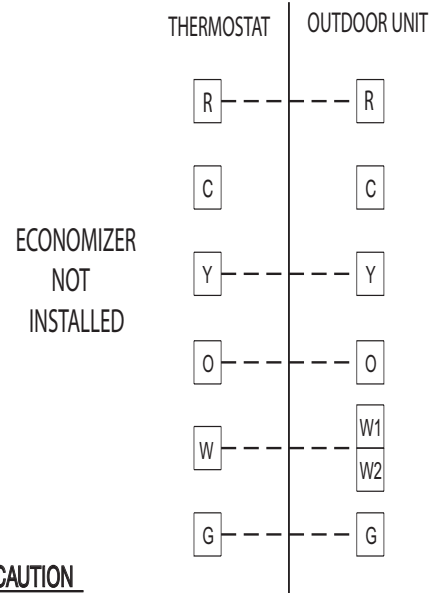

### CAUTION

Do not connect **C** connections except when required by the indoor thermostat. Refer to the thermostat installation instructions.

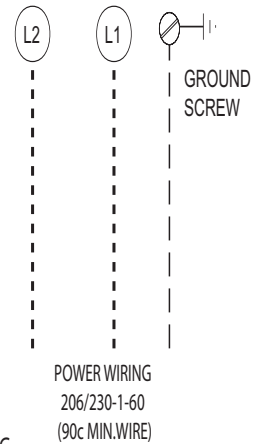

POWER WIRING  
24V CONTROL WIRING (NEC CLASS 2)

\*W1, W2 CAN BE USED TO STAGE ELECTRIC HEAT ACCESSORY ON 15 & 20 kW MODELS.  
\* 5, 7 & 10 kW HEATER ACCESSORY FUNCTION OFF W1 ONLY.

### TYPICAL WIRING CONNECTION 1 PHASE

Figure 5

**Minimum Required Surface Area  
for Disposable Filters**

Cooling BTU/Hr	Filter Area
24,000 (2 Ton)	480 Square Inches
30,000 (2 - 2.5 Ton)	600 Square Inches
36,000 (3 Ton)	600 Square Inches
42,000 (3.5 Ton)	650 Square Inches
48,000 (4 Ton)	800 Square Inches
60,000 (5 Ton)	900 Square Inches

Unit Model	Internal Filter Size
RPHP/RHP 24, 30, 36	28" X 25"
RPHP/RHP 42 - 60	30" X 30"

**Table 2**

**Condensate Drain**

The package unit is equipped with a 3/4" fpt coupling for condensate line connection. Plumbing must conform to local codes. Use a sealing compound on the male adaptor pipe threads.

**The condensate drain line must be properly trapped and routed to a suitable drain.** See Figure 6 for proper drain arrangement. The drain line must pitch to an open drain or pump to prevent clogging of the line. Seal around the drain connection with suitable material to prevent air leakage into the return air system.

**Heater Kit Accessory (if used)**

The unit is fully equipped for cooling operation without auxiliary heat. A heater kit accessory may also be used. To install the heater kit accessory (see Figure 7):

1. Disconnect the power and open the main control access.
2. Disconnect the plug separating the high voltage wire harness. Remove the high voltage wire harness plug and discard.

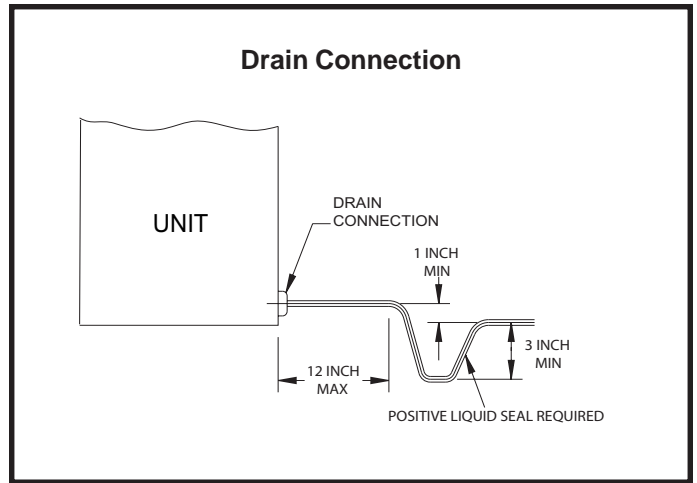

**Figure 6**

3. Remove the heater blockoff by removing the four screws holding it in place. Cut away the insulation covering the opening, using the hole in the panel as a template.
4. Insert the heater into the control panel and fasten in the same mounting holes.
5. Plug the heater wiring harness into the wire harness on the control assembly. Field wiring of the auxiliary heater is separate from the unit power supply. Wire the power supply wiring for the heater to the appropriate connections on the heater kit.

**Crankcase Heater (if used)**

Some models may be equipped with insertion crankcase heaters to prevent excessive migration of liquid refrigerant into the compressor. The following steps should be taken on initial start-up to prevent possible compressor damage. The procedure must be followed at initial start-up as well as any time power has been interrupted for 12 hours or longer.

1. Insure that the room thermostat is in OFF position to prevent the compressor from starting.
2. Apply the main power supply to the outdoor unit. This will energize the crankcase heater.
3. Maintain power to the unit for a minimum of 8 hours.
4. After reaching minimum elapsed time, the unit can be safely started.

Except as required for safety while servicing, **do not open the system disconnect switch.**

### Removal of Unit from Common Venting System

When an existing furnace is removed from a common venting system serving other appliances, the venting system is likely to be too large to properly vent the remaining attached appliances. The following test should be conducted with each appliance while the other appliances connected to the common venting system are not in operation.

1. Seal any unused openings in the common venting system.
2. Visually inspect the venting system for proper size and horizontal pitch and determine there is no blockage or restriction, leakage, corrosion, or other deficiencies which could cause an unsafe condition.
3. Insofar as is practical, close all building doors and windows between the space in which the appliances remaining connected to the common venting system are located and other spaces in the building. Turn on clothes dryers and any appliance not connected to the common venting system. Turn on exhaust fans, such as range hoods and bathroom exhausts, so they will operate at maximum speed. Do not operate a summer exhaust fan. Close fireplace dampers.
4. Following the lighting instructions, place the unit being inspected in operation. Adjust the thermostat so the appliance will operate continuously.
5. Test for spillage at the draft control relief opening after 5 minutes of main burner operation. Use the flame of a match or candle.
6. Follow the preceding steps for each appliance connected to the common venting system.
7. After it has been determined that each appliance remaining connected to the common venting system properly vents when tested as outlined above, return doors, windows, exhaust fans, fireplace dampers, and any other fuel burning appliance to their previous condition of use.
8. If improper venting is observed during any of the above tests, the common venting system must be corrected. **See National Fuel Gas Code, ANSI Z223.1 (latest edition) or CAN/CGA B149.1 & .2 Canadian Installation Codes to correct improper operation of common venting system.**

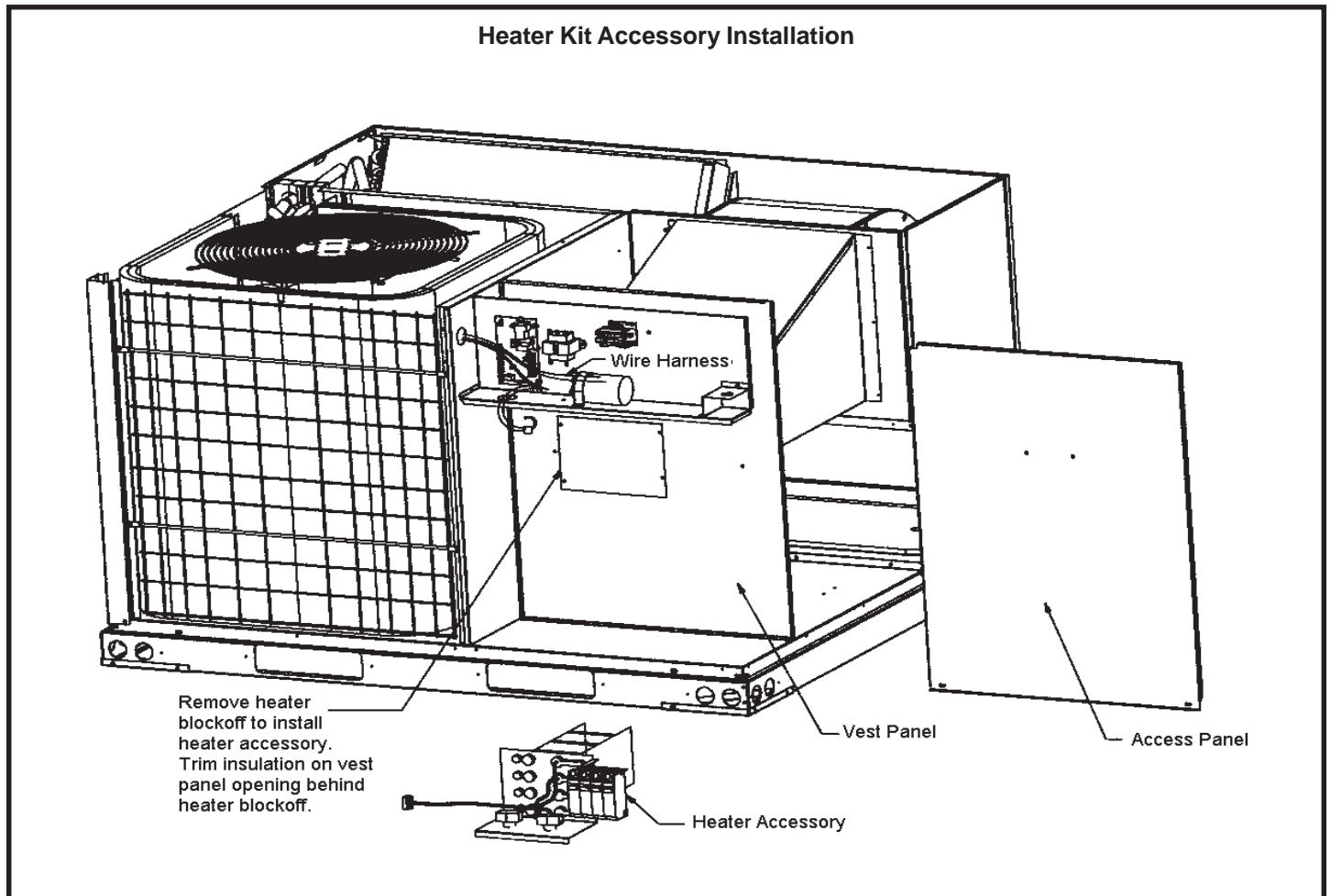

Figure 7

## Sequence of Operation

### Cooling

When the thermostat is in the cooling mode, the O circuit is powered which energizes the reversing valve. Upon cooling demand, the thermostat closes circuit R and Y. Closing R and Y closes the unit contactor, starting the compressor and outdoor fan. The thermostat automatically closes R to G circuit which also brings on the indoor blower at the same time. Upon satisfying cooling demand, the thermostat will open the above circuits and open the main contactor, stopping the compressor and outdoor fan. If the unit is equipped with a delay timer, the blower will continue to operate for 90 seconds which improves system efficiency.

### Heating

Upon heating demand, the thermostat closes circuit R to Y, which closes the unit contactor, starting the compressor and outdoor fan. The reversing valve is not energized in the heating mode. The thermostat again automatically brings on the indoor fan at the same time. Upon satisfying heating demand, the thermostat opens above circuits and stops unit operation.

### Defrost System

The defrost system includes two components: the defrost thermostat and the defrost control.

### Defrost Thermostat

The defrost thermostat is located on the liquid line between the check/expansion valve and the distributor. When the defrost thermostat senses 42°F or cooler, the thermostat contacts close and send a signal to the defrost control board to start the defrost timing. It also terminates defrost when the liquid line warms up to 70°F.

### Defrost Control

The defrost control board includes the combined functions of time/temperature defrost control, defrost relay, diagnostic LEDs and terminal strip for field wiring connections (see Figure 8).

The control provides automatic switching from normal heating operation to defrost mode and back. During the compressor cycle (call for defrost), the control accumulates compressor run time at 30, 60, 90 minute field-adjustable intervals. If the defrost thermostat is closed when the selected compressor run time interval ends, the defrost relay is energized and the defrost begins.

### Defrost Control Timing Pins

Each timing pin selection provides a different accumulated compressor run time period during one thermostat run cycle. This time period must occur before a defrost cycle is initiated. The defrost interval can be adjusted to 30 (T1), 60 (T2), or 90 (T3) minutes. The defrost timing jumper is factory installed to provide a 60-minute defrost interval. If the timing selector jumper is not in place, the control defaults to a 90-minute defrost interval. The maximum defrost period is 14 minutes and cannot be adjusted.

A test option is provided for troubleshooting. The test mode may be started any time the unit is in the heating mode and the defrost thermostat is closed or jumpered. If the jumper is in the TEST position at power up, the control will ignore the test pins. When the jumper is placed across the TEST pins for 2 seconds, the control will enter the defrost mode. If the jumper is removed before an additional 5-second period has elapsed (7 seconds total), the unit will remain in defrost mode until the defrost thermostat opens or 14 minutes have passed. If the jumper is not removed until after the additional 5-second period has elapsed, the defrost will terminate and the test option will not function again until the jumper is removed and reapplied.

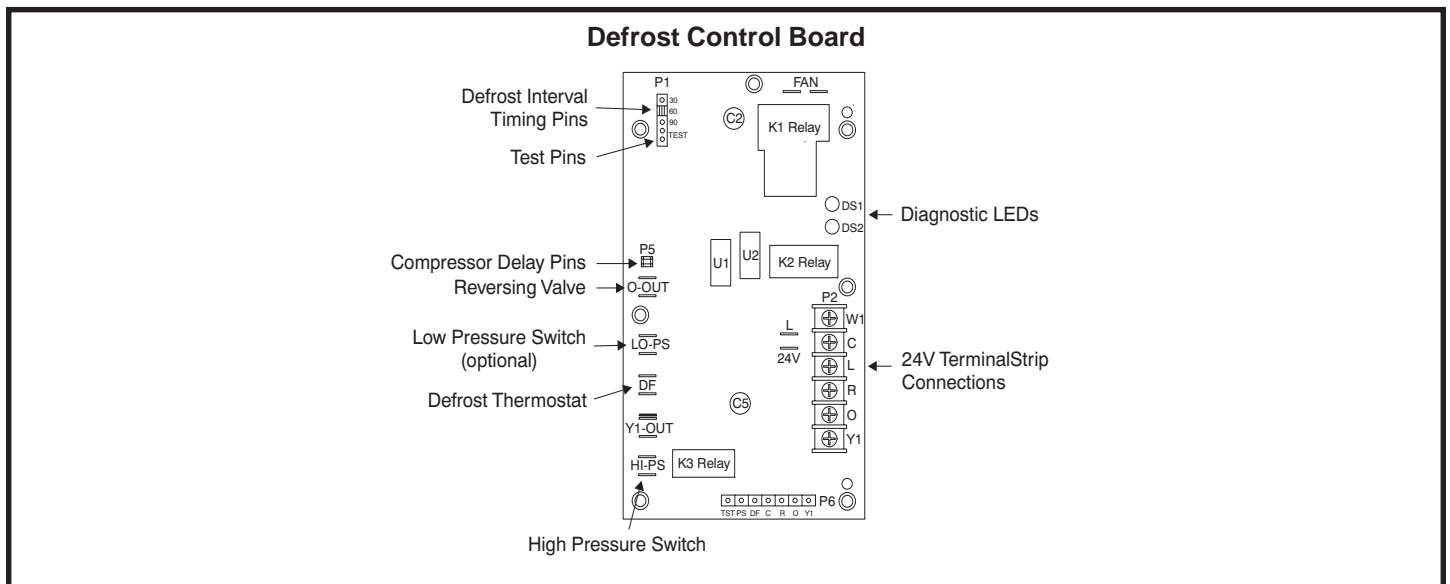

Figure 8

### Compressor Delay

The defrost board has a field-selectable function to reduce occasional sounds that may occur while the unit is cycling in and out of the defrost mode. The compressor will be cycled off for 30 seconds going in and out of the defrost mode when the compressor delay jumper is removed.

NOTE: The 30-second “off” cycle is not functional when jumpering the TEST pins.

### Time Delay

The timed-off delay is 5 minutes long. The delay helps to protect the compressor from short cycling in case the power to the unit is interrupted or a pressure switch opens. The delay is bypassed by placing the timer select jumper across the TEST pins for 0.5 seconds.

### Pressure Switch Circuit

High and low pressure switches are connected to the defrost control board on heat pump models. Air conditioning models have a high pressure switch installed in line with compressor contactor coil. (see Figure 8 on page 8).

**During a single demand cycle, the defrost control will lock out the unit after the fifth time that the circuit is interrupted by any pressure switch wired to the control board. In addition, the diagnostic LEDs will indicate a locked-out pressure switch after the fifth occurrence of an open pressure switch (see Table 3).**

**The unit will remain locked out until power to the board is interrupted, then re-established, or until the jumper is applied to the TEST pins for 0.5 seconds.**

NOTE: The defrost control board ignores input from the low pressure switch terminals as follows:

- During the TEST mode
- During the defrost cycle
- During the 90-second start-up period
- For the first 90 seconds each time the reversing valve switches heat/cool modes

**If the TEST pins are jumpered and the 5-minute delay is being bypassed, the LO PS terminal signal is not ignored during the 90-second start-up period.**

### Diagnostic LEDs

The defrost board uses two LEDs for diagnostics. The LEDs flash a specific sequence according to the condition as shown in Table 3.

Defrost Control Board Diagnostic LEDs		
Mode	Green LED (DS2)	Red LED (DS1)
No Power to Board	Off	Off
Normal Operation/ Power to Board	Simultaneous Slow Flash	
Anti-Short Cycle Lockout	Alternating Slow Flash	
Low Pressure Switch Fault	Off	Slow Flash
Low Pressure Switch Lockout	Off	On
High Pressure Switch Fault	Slow Flash	Off
High Pressure Switch Lockout	On	Off

Table 3

### System Performance

For maximum performance of this heat pump system, the operating temperatures and pressures should be checked and superheat determined at Standard ARI test conditions of 82°F outdoor – 80°F indoor dry bulb/67°F wet bulb. If superheat measured deviates from the values given in Table 4 on page 10, refrigerant charge should be adjusted accordingly for maximum performance.

## MAINTENANCE

### ⚠ WARNING

Before performing maintenance operations on the system, shut off all electrical power to the unit. Turn off accessory heater power switch if applicable. Electrical shock could cause personal injury or death.

Periodic inspection and maintenance normally consists of changing or cleaning the filters and cleaning the outdoor coil. On occasion, other components may also require cleaning.

**Filters**

Filters are not supplied with the unit. Inspect once a month. Replace disposable or clean permanent type as necessary.

**Do not replace permanent type with disposable.**

**Motors**

Indoor and outdoor fan and vent motors are permanently lubricated and require no maintenance.

Some models may be equipped with a permanent magnet, constant torque indoor blower motor. These motors remain energized and are controlled by 24V signals. For high static applications, use tap 3 for cooling speed and tap 5 for heating speed. Refer to the heater install label for limitations to blower tap selection on heating speeds.

**Outdoor Coil**

Dirt and debris should not be allowed to accumulate on the outdoor coil surface or other parts in the air circuit. Cleaning should be as often as necessary to keep the coil clean. Use a brush, vacuum cleaner attachment, or other suitable means. If water is used to clean the coil, be sure the power to unit is shut off prior to cleaning. **Care should be used when cleaning the coil so that the coil fins are not damaged.**

### Suction Superheat

Outdoor Unit Model	Suction Superheat @ARI Conditions 82° OD 80° IDDB/67° IDWB
RPHP/RHP13(*) 24	17
RPHP/RHP13(*)30	20
RPHP/RHP13(*)36	16
RPHP/RHP13(*)42	17
RPHP/RHP13(*)48	19
RPHP/RHP13(*)60	19
RPCE/RCE13(*)24	18
RPCE/RCE13(*)30	17
RPCE/RCE13(*)36	17
RPCE/RCE13(*)42	16
RPCE/RCE13(*)48	15
RPCE/RCE13(*)60	13

\* These letters will vary according to unit series.

**Table 4**

### DIAGNOSTIC DISPLAY

Description	DS1 (GREEN)	DS2 (RED)
No Power to Control	OFF	OFF
Normal Operation / Power to Control	Simultaneous Slow Flash	
Anti-Short Cycle Lockout	Alternate Slow Flash	
Low Pressure Switch Fault	OFF	Slow Flash
Low Pressure Switch Lockout	OFF	ON
High Pressure Switch Fault	Slow Flash	OFF
High Pressure Switch Lockout	ON	OFF

NOTE: TAP1 FOR FAN ONLY  
TAP 2 FOR COOLING  
TAP3 FOR HIGH STATIC COOLING  
TAP4 AND TAP5 FOR ELECTRIC HEAT

REFER TO HEATING LABEL

NOTE: Because the Pressure Switches are monitored only when "TI" (Tap1) is active, the code for pressure switch open will not be seen when "TI" is off. Instead, the "Normal Operation" or "Anti Short Cycle" code will be seen.

Also, when a pressure switch opens and causes a short cycle lockout, the pressure switch open code will be seen until it closes, then the short cycle lockout code will flash unless it has already expired.

W1 & W2 CAN BE USED TO REPAIR  
ELECTRIC HEAT ACCESSORY ON  
S, T, S & 100W HEATER ACCESSORIES  
FUNCTION OFF W1 ONLY.

### CONNECTION DIAGRAM, HEAT PUMP - PACKAGED

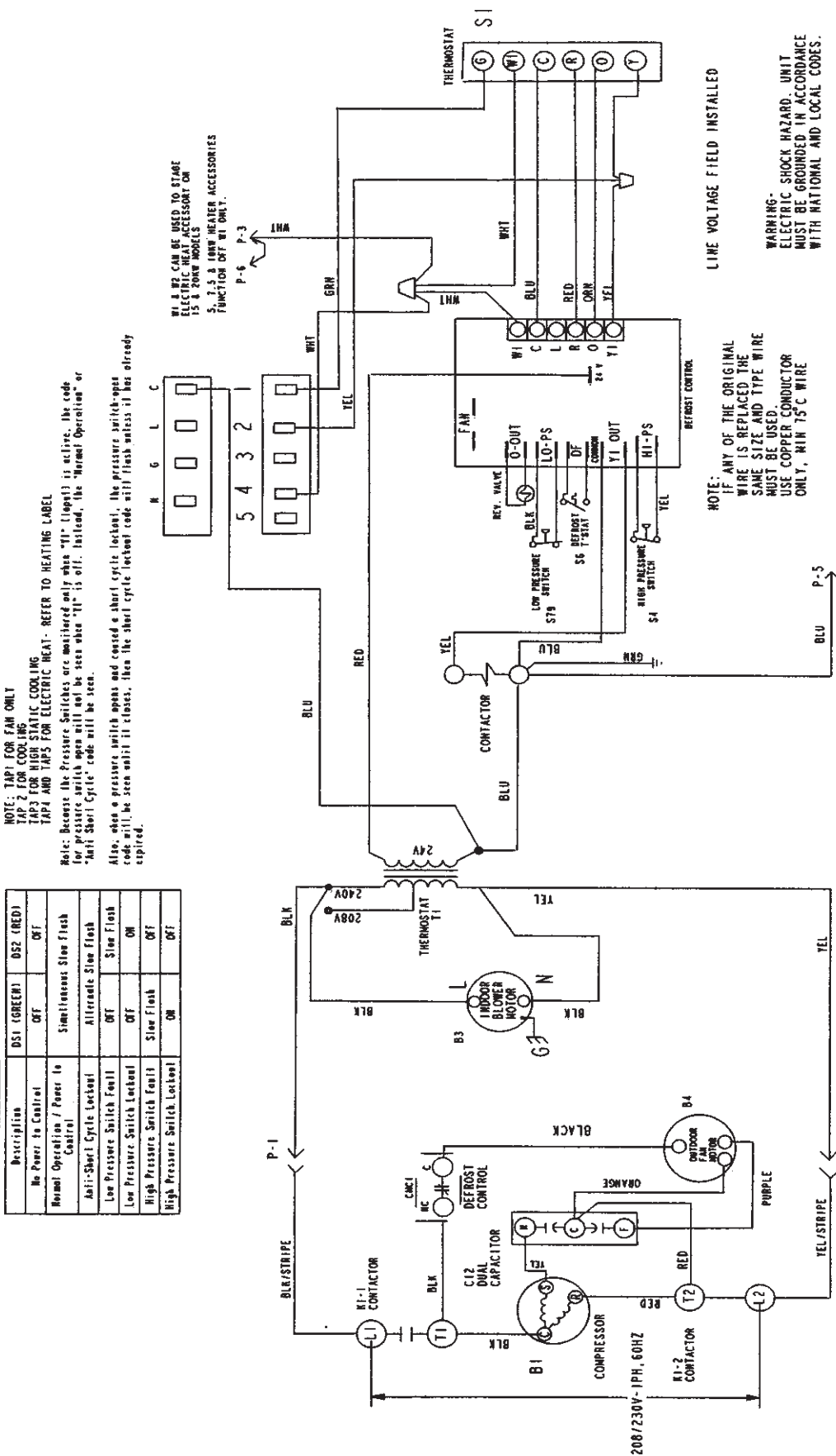

LINE VOLTAGE FIELD INSTALLED

NOTE: IF ANY OF THE ORIGINAL WIRE IS REPLACED THE SAME SIZE AND TYPE WIRE MUST BE USED. USE COPPER CONDUCTOR ONLY, MIN 75°C WIRE

WARNING - ELECTRIC SHOCK HAZARD. UNIT MUST BE GROUNDED IN ACCORDANCE WITH NATIONAL AND LOCAL CODES.

P-4

537201-01

Figure 9

CONNECTION DIAGRAM, ELECTRIC/ ELECTRIC - PACKAGED

NOTE: TAP1 FOR FAN ONLY  
 TAP2 FOR COOLING  
 TAP3 FOR HIGH STATIC COOLING  
 TAP4 AND TAPS FOR ELECTRIC HEAT- REFER TO HEATING LABEL

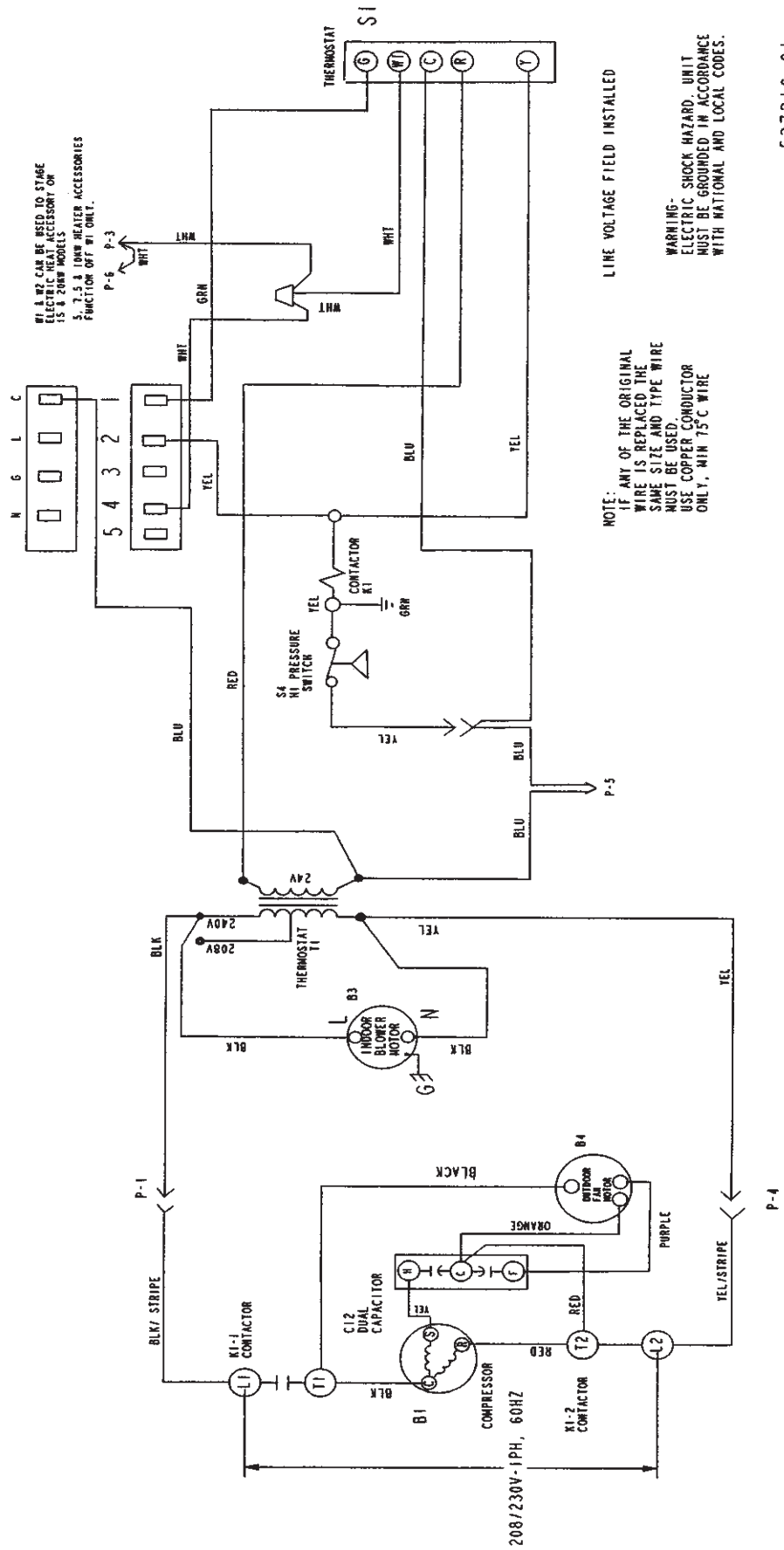

#1 & #2 CAR BE USED TO STAGE  
 ELECTRIC HEATING ON  
 15.5 & 16.5 INCH MODELS  
 5, 7 & 8 INCH HEATER ACCESSORIES  
 FUNCTION OFF #1 ONLY.  
 P-6 P-3  
 WHI  
 LHM

LINE VOLTAGE FIELD INSTALLED

NOTE: IF ANY OF THE ORIGINAL  
 WIRE IS REPLACED THE  
 SAME SIZE AND TYPE WIRE  
 MUST BE USED.  
 USE COPPER CONDUCTOR  
 ONLY, MIN 75°C WIRE

WARNING-  
 ELECTRIC SHOCK HAZARD. UNIT  
 MUST BE GROUNDED IN ACCORDANCE  
 WITH NATIONAL AND LOCAL CODES.

537216-01

Figure 10

**ALLIED AIR ENTERPRISES  
EQUIPMENT LIMITED WARRANTY  
APPLIES IN U.S.A. AND CANADA ONLY  
FAILURE TO MAINTAIN YOUR EQUIPMENT WILL VOID THIS WARRANTY**

**COVERED EQUIPMENT**

The following Allied Air Enterprises heating and cooling equipment is covered by the Limited Warranty,

**Condensing Units:** 2SCU13, 4SCU13, 4SCU14, 4SCU16, 4SCU18, 2AC13, 2AC14, 4AC13

**Heat Pumps:** 2SHP13, 4SHP13, 2SHP14, 4SHP14, 4SHP16, 4SHP18, 2HP13, 2HP14, 4HP13

**Gas Furnaces:** G1N80, G1D80, G2D80, G1D91, G1D93, G2D93, G2D95, FPBB, CG80, CG90, CG92, CG93, CG95

**Oil Furnaces:** LBR80, LBF80, LHF80, LUF80, LHF80, RLUF, RLBF, RLBR, RLBU, RLHF, RLHR

**Electric Furnaces:** EFC, EFV

**Evaporator Coils:** EC, EU, EH, EM

**Air handlers:** BCS2, RBSC2

**Package Equipment:** 2PCE13, 4PCE13, 4PCE15, 2PGE13, 4PGE13, 4PGE15, 2PHP13, 4PHP13, 4PHP15, 2SG13, 2SH13, 2SA13, RGE13, RPGE13, RHP13, RCE13, RPHP13, RPCE13

**PARTS and COMPRESSOR COVERAGE**

The covered equipment and covered parts and compressor are warranted by Allied Air for a period of five (5) years from the date of the original installation, when installed in a residential application (which includes homes, duplexes, apartments and condominiums). The covered equipment and covered parts are warranted for a period of one (1) year and compressor is warranted for five (5) years by Allied Air from the date of the original installation, when installed in non-residential applications. If, during this period, a covered component fails because of a manufacturing defect, Allied Air will provide a free replacement part to the owner through a licensed service contractor utilizing an Allied Air distributor. You must pay shipping charges and all other costs of warranty service. Allied Air will not pay labor involved in diagnostic calls or in removing, repairing, servicing or replacing parts. Such cost may be covered by a separate warranty provided by the installer.

**HEAT EXCHANGER EXTENDED COVERAGE**

All covered heat exchangers are warranted by Allied Air for a period of twenty (20) years from the date of original installation. Heat exchangers in all non-residential applications are warranted for a period of ten (10) years.

Heat Exchanger Availability: If a replacement heat exchanger is no longer available for a unit covered by this warranty, Allied Air will allow a credit toward the purchase of an equivalent Allied Air furnace (at the current suggested distributor's cost).

**NOTE:** If the date of original installation cannot be verified, the warranty period will be deemed to begin ninety (90) days after the date of manufacture.

**EXCLUDED COMPONENTS**

The following components are not covered by this warranty: cabinets, cabinet pieces, air filters, driers, refrigerant, refrigerant line sets, belts, wiring, fuses, oil nozzles, unit accessories and any parts not affecting unit operation

**CARE OF EQUIPMENT**

Your new Allied Air unit must be properly installed, operated and maintained in accordance with the unit installation, operation and maintenance instructions provided with each Allied Air unit. Failure to provide maintenance per Allied Air instructions will void this warranty.

**WARRANTY PROCEDURE**

When service or warranty parts are required:

1. Call your local licensed service dealer or contractor
2. If the installing dealer is unable to provide warranty service, check online at [www.alliedair.com](http://www.alliedair.com).
3. Be prepared to furnish the following information:
  - a. complete model and serial number
  - b. proof of required periodic maintenance, installation date and location
  - c. an accurate description of the problem

**WARRANTY LIMITATIONS**

1. This warranty is void if the covered equipment is removed from the original installation site.
2. This warranty does not cover damage or defect resulting from:
  - a. flood, wind, fire, lightning, mold, or installation and operation in a corrosive atmosphere, or otherwise in contact with corrosive materials (chlorine, fluorine, salt, recycled waste water, urine, fertilizers, or other damaging substances or chemicals); accident, or neglect or unreasonable use or operation of the equipment including operation of electrical equipment at voltages other than the range specified on the unit nameplate (includes damages caused by brownouts).
  - b. modification, change or alteration of the equipment, except as directed in writing by Allied Air.
  - c. operation with system components (indoor unit, outdoor unit and refrigerant control devices) which are not an ARI match or meet the specifications recommended by Allied Air.
  - d. operation of furnaces with return air temperatures of less than 60°F (16°C) or operation of a furnace field installed downstream from a cooling coil.
  - e. use of contaminated or refrigerant not compatible with the unit.

The installation of replacement parts under the terms of this warranty does not extend the original warranty period.

Allied Air makes no express warranties other than the warranty specified above. All implied warranties, including the implied warranties of merchantability and fitness for a particular purpose, are excluded to the extent to a period legally permissible. Should such exclusion or limitation of the warranty be unenforceable, such implied warranties are in any event limited to a period of one (1) year. Liability for incidental and consequential damages is excluded. Some states do not allow limitation of incidental damages, so the limitations or exclusions may not apply to you. Allied Air will not pay electricity or fuel costs, or increases in electricity or fuel costs, for any reason whatsoever, including additional or unusual use of supplemental electric heat. This warranty does not cover lodging expenses or labor charges.

Allied Air shall not be liable for any default or delay in performance under this warranty caused by any contingency beyond its control.

This warranty gives you specific legal rights, and you may also have other rights which vary from state to state.

**NOTE TO CUSTOMER:**

Please complete information below and retain this warranty for your records and future reference.

Outside Unit Model Number: \_\_\_\_\_ Serial Number: \_\_\_\_\_ Installed Date: \_\_\_\_\_

Furnace / Air Handler: \_\_\_\_\_ Serial Number: \_\_\_\_\_ Installed Date: \_\_\_\_\_

Indoor Coil Model Number: \_\_\_\_\_ Serial Number: \_\_\_\_\_ Installed Date: \_\_\_\_\_

Installing Company Name: \_\_\_\_\_ Phone: \_\_\_\_\_

Installing Company Address: \_\_\_\_\_ State/Province: \_\_\_\_\_ Zip/Postal Code: \_\_\_\_\_



215 Metropolitan Drive - West Columbia - SC - 29170  
© 2008 Allied Air Enterprises Litho U.S.A. FORM W-2008-2 (4/30/2009)

## **LIMITED EXTENDED PARTS WARRANTY**

Allied Air Enterprises, Inc. ("Allied") provides its air conditioning and heating products with a standard five-year parts warranty. This limited extended parts warranty is in addition to and is intended to supplement Allied's standard 5-year parts warranty. As such, this limited extended warranty provides for a total of 10-years of limited warranty coverage (Standard 5-Year Limited Parts Warranty plus Additional 5-Year Limited Extended Parts warranty).

### **EXTENDED COVERAGE -**

#### **PARTS/COMPRESSORS**

The covered equipment and parts are warranted by Allied for a total of **10 YEARS** (standard 5 Year Limited Parts Warranty) from installation, except as provided below.

#### **HEAT EXCHANGERS**

The covered residential heating equipment's heat exchanger is warranted by Allied for a Limited Lifetime (standard 20 Year Limited Warranty) from date of original installation, except as provided below.

This warranty applies only to the original purchaser of the unit and cannot be transferred. If during this period, a covered part fails because of a defect in materials or workmanship under normal use and maintenance, Allied will provide a free replacement part to the purchaser through an Armstrong Air, Air Ease, Ducane or Concord dealer or other licensed service contractor through an authorized Allied distributor. The purchaser must pay shipping costs, including labor, of the warranty service.

### **EXCLUDED COMPONENTS -**

The following components are expressly not covered by this limited warranty: cabinets, cabinet pieces, air filters, driers, refrigerant, refrigerant line sets, belts, wiring, fuses, oil nozzles, and unit accessories, R-22 compressors, and any parts not affecting unit operation.

## **COVERAGE REQUIREMENTS -**

1. The unit is an Armstrong Air, Air ease, Ducane, or Concord branded unit;
2. The unit is installed in a residential application, which is an owner-occupied single-family residence. No commercial applications are allowed;
3. **The unit is properly registered at ([www.alliedair.com](http://www.alliedair.com)) with Allied Air Enterprises within 60-days after the original date of installation or occupancy.<sup>1</sup> To register follow the directions and complete the on line warranty registration at ([www.alliedair.com](http://www.alliedair.com)). For customer inquiries contact Allied Air at 1-800-448-5872.**
4. The unit is part of a complete ARI matched system and installed by a state certified or licensed contractor in accordance with the unit installation, operation, and maintenance instructions provided with the unit.
5. Coils and air handlers are covered only when they are branded Armstrong Air, Air ease, Ducane, or Concord and are purchased and installed as a system along with a qualifying unit. (Third party coils are not covered).
6. Installation takes place on or after October 3, 2008.

If this extended warranty does not apply, then parts are warranted for the standard warranty period of **5 YEARS** and all heat exchangers for **20 YEARS**. If the standard warranty periods differ from the original warranty certificate, the periods stated on the original warranty certificate apply.

This limited extended warranty does not apply to, and no warranty is offered by Allied, on any unit ordered over the internet. Proof of purchase may be required.

Any part replaced pursuant to this limited extended warranty is warranted only for the unexpired portion of the limited extended warranty term applying to the original part. The installation of replacement parts under the terms of this limited extended warranty does not extend the warranty period.

This limited extended warranty is an extension of Allied's standard warranty. **ANY IMPLIED WARRANTY OF MERCHANTABILITY OR FITNESS FOR A PARTICULAR PURPOSE ON THIS PRODUCT IS LIMITED IN DURATION TO THE TERM OF THIS LIMITED EXTENDED WARRANTY.** Some states and provinces do not allow limitations on how long an implied warranty lasts, so the above limitation may not apply to you.

**ALLIED SHALL IN NO EVENT BE LIABLE FOR INCIDENTAL OR CONSEQUENTIAL DAMAGES, INCLUDING BUT NOT LIMITED TO EXTRA UTILITY EXPENSES OR DAMAGES TO PROPERTY.** Some states and provinces do not allow the exclusion or limitation of incidental or consequential damages, so the above limitation or exclusion may not apply to you.

Allied is not responsible for:

1. Damage or repairs required as a result of flood, fire, wind, lightning strike (to the home or unit), corrosive atmosphere, contact with corrosive material (Chlorine, fluorine, salt, recycled waste water, fertilizers or other damaging substances) or other conditions beyond the control of Allied;
2. Use of parts, accessories, or refrigerant not compatible with the unit;
3. Modification, change or alteration of the unit, except as expressly directed in writing by Allied;
4. Improper use, accident, neglect or unreasonable use or operation of the unit, including operation of electrical equipment at voltages other than the range specified on the unit nameplate;
5. Operation with system parts (indoor unit, outdoor unit and refrigerant control devices) which are not ARI matched or do not meet the specifications recommended by Allied;
6. Damage or repairs required as a consequence of faulty or installation or application;
7. Normal maintenance as described in the installation and operating manual, such as cleaning of coils, filter cleaning and/or replacement and lubrication; and
8. Changes in the appearance or sound of the unit that do not affect its performance.

**The parties intend this writing as a final expression of their agreement with respect to warranties. Allied makes no other warranty beyond that which is expressly contained in this writing.**

Allied shall not be liable for any default or delay in performance under this warranty caused by any contingency beyond its control, including the unavailability of replacement parts.

This warranty gives you specific legal rights, and you may also have other rights that vary from state to state or province to province.

#### **Steps for getting replacement parts under this limited extended warranty:**

**If you suspect a defect in your equipment, please contact the installer of the unit to obtain assistance. If unsuccessful, please contact an Allied dealer or distributor in your area. If unable to obtain local assistance, refer to Allied's website ([www.alliedair.com](http://www.alliedair.com)) or contact Allied at 800-448-5872.**

<sup>1</sup> Excludes residents of states or provinces where registration requirements are prohibited, such as California and Quebec. Residents of these states or provinces may either register as noted above or provide proof of when the unit was purchased and installed, such as an original invoice from the contractor with the Owner's name, address, purchase date, serial and model number.