

Split System Heat Pump

13
SEER

2HP13 Features and Benefits

- Durable scroll compressors, with internal pressure relief valves and inherent thermal protection
- High-quality condenser coil with copper tubing and enhanced louvered fin for maximum heat transfer capacity
- Top discharge directs hot air and sound away from living area and shrubbery
- All units are factory run tested
- Available with louvered panel or wire guard coil protection option
- Easy access to electrical panels, pre-wired for easy hook-up
- Hinged control panel allows simple access to internal components
- Bi-directional liquid line filter drier factory installed
- Discharge muffler for quiet operation
- Reliable, solid state time / temperature defrost control, with field selectable 30/60/90 minute intervals
- Low pressure switch for loss of charge protection (factory installed)
- Integrated defrost control with LED diagnostics is quiet shift capable
- Short cycle protection (factory installed)
- All units ETL, ETLC approved and ARI listed
- Charged for 15 feet of interconnecting tubing
- Select models meet 76dBA and include compressor sound blanket
- 10 year limited parts warranty available (5 year compressor). See limited warranty document for details.



L Model



B Model

Model Number Guide

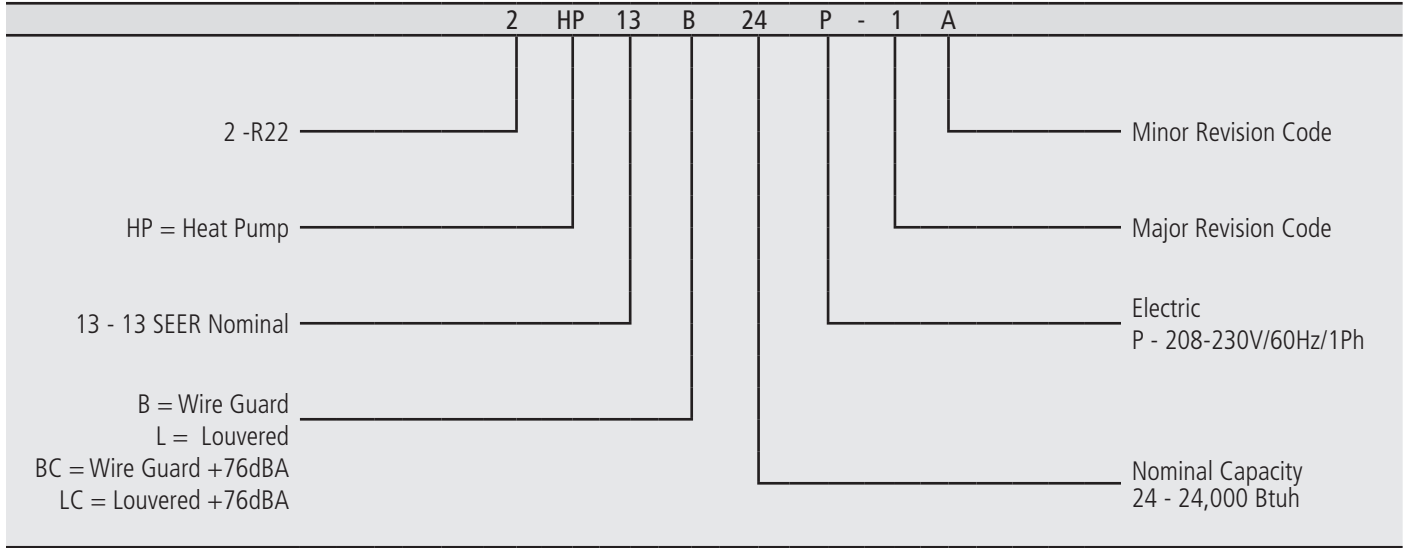

Physical and Electrical Data

Model	Volts/Hz/ Phase	Voltage Range	Min. Circuit Amp.	Max. Over- current Device (amps)	Compressor		Fan Motor			Refrig. Charge (oz.) ‡	Weight (lbs.)
					Rated Load (amps)	Locked Rotor (amps)	Rated Load (amps)	Rated HP	Nom. RPM		Wire Guard/ Louvered
2HP13**18P	230/60/1	197/253	11.5	20	8.6	38	0.7	1/10	1075	130	183/198
2HP13**24P	230/60/1	208/230	15.3	25	11.4	56	0.7	1/10	1075	130	188/203
2HP13**30P	230/60/1	208/230	17.9	30	13.6	67	1.1	1/5	1075	144	196/212
2HP13**36P	230/60/1	208/230	21.7	35	16.4	83	1.2	1/4	1075	148	205/221
2HP13*42P	230/60/1	208/230	23.6	40	17.9	88	1.2	1/4	1075	206	215/227
2HP13*48P	230/60/1	208/230	26.8	45	20.0	104	1.2	1/4	1075	306	227/243
2HP13*60P	230/60/1	208/230	31.0	50	22.1	137	1.2	1/4	1075	284	245/261

** - B, L, BC, LC

‡ Charge amount is with 15 feet line set

* - B, L

Dimensions (in.) and Sound Ratings

Model	Dimensions			B, L Sound Rating (dBA)	BC, LC Sound Rating (dBA)
	A - width (in.)	B - depth (in.)	C - height (in.)		
2HP13**18P	30	30	33.75	79	76
2HP13**24P	30	30	33.75	80	76
2HP13**30P	30	30	27.75	76	76
2HP13**36P	30	30	25.75	78	76
2HP13*42P	30	30	25.75	76	---
2HP13*48P	30	30	27.75	77	---
2HP13*60P	30	30	41.75	76	---

** - B, L, BC, LC

* - B, L

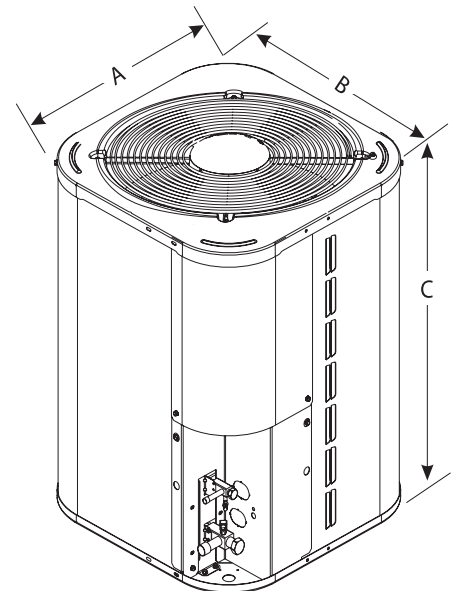

Cooling Performance with Evaporator Coils

Outdoor Model	Indoor Model		Cooling				Heating					Refrigerant Connection				Indoor Metering Device				
	Piston or Field Installed TXV	Factory Installed TXV	SEER	EER	Rated ARI Capacity ¹	Rated Sensible Capacity	HSPF	47°		17°		CFM	Outdoor		Indoor		Suction	Liquid	Req'd Indoor ² Orifice	Optional Field Installed Orifice
								Btuh	COP	Btuh	COP		Suction	Liquid	Suction	Liquid				
2HP13**18P	E(C,H,M,U)1P36(A,B,C)+TXV	E(C,H,M,U)2T36(A,B,C)	13.00	12.00	19,000	15,000	7.70	18,000	2.88	11,900	1.84	650	3/4	3/8	3/4	3/8	3/4	3/8	---	H2TXV01
2HP13**24P	E(C,H,M,U)1P29A+TXV	E(C,H,M,U)2T29A	13.00	11.50	24,000	19,700	7.70	22,000	2.88	13,400	2.18	850	3/4	3/8	3/4	3/8	3/4	3/8	---	H2TXV01
	E(C,H,M,U)1P36(A,B,C)+TXV	E(C,H,M,U)2T36(A,B,C)	13.00	11.50	24,400	19,700	7.70	22,600	2.88	13,400	2.22	850	3/4	3/8	3/4	3/8	3/4	3/8	---	H2TXV01
2HP13**30P	E(C,H,M,U)1P36(A,B,C)+TXV	E(C,H,M,U)2T36(A,B,C)	13.00	11.00	29,000	23,800	7.70	25,800	3.30	15,900	2.14	1085	3/4	3/8	3/4	3/8	3/4	3/8	---	H2TXV01
2HP13**36P	E(C,H,M,U)1P43B	E(C,H,M,U)2T43B	13.00	11.00	35,000	25,800	7.70	35,000	3.00	21,800	2.04	1250	3/4	3/8	7/8	3/8	3/4	3/8	.076	H2TXV01
	E(C,H,U)1P49C	E(C,H,U)2T49C	13.00	11.00	35,000	25,800	7.70	35,000	3.00	21,800	2.04	1250	3/4	3/8	7/8	3/8	3/4	3/8	.076	H2TXV01
2HP13*42P	E(C,H,U)1P49C	E(C,H,U)2T49C	13.00	12.00	40,000	30,000	7.70	38,000	3.06	21,800	2.38	1450	7/8	3/8	7/8	3/8	7/8	3/8	.076	H2TXV02
	E(C,U)1P60D	E(C,U)2T60D	13.00	12.00	40,000	30,000	7.70	38,000	3.06	22,000	2.38	1450	7/8	3/8	7/8	3/8	7/8	3/8	.076	H2TXV02
	EH1P49D	---	13.00	12.00	40,000	30,000	7.70	38,000	3.06	21,800	2.38	1450	7/8	3/8	7/8	3/8	7/8	3/8	.076	H2TXV02
2HP13*48P	E(C,H,U)1P49C	E(C,H,U)2T49C	13.00	11.50	46,000	34,500	7.70	45,000	2.96	29,400	2.28	1650	7/8	3/8	7/8	3/8	7/8	3/8	.082	H2TXV02
	E(C,H,U)1P62D	E(C,H,U)2T62D	13.00	11.50	46,500	35,000	7.70	45,500	2.96	30,000	2.32	1650	7/8	3/8	7/8	3/8	7/8	3/8	.082	H2TXV02
2HP13*60P	E(C,H,U)1P62C	E(C,H,U)2T62C	13.00	11.50	56,000	40,900	7.70	54,000	3.40	32,000	2.58	1950	7/8	3/8	7/8	3/8	1-1/8	3/8	.098	H2TXV02
	E(C,H,U)1P62D	E(C,H,U)2T62D	13.00	11.50	54,000	39,400	7.70	52,000	3.40	31,600	2.54	1950	7/8	3/8	7/8	3/8	1-1/8	3/8	.098	H2TXV02

** - B, L, BC, LC
 * - B, L

¹ Certified in accordance with Unitary Air Conditioner Certification Program, which is based on ARI Standard 210/240.

² Required to achieve ARI rating.

A blower time delay is required to achieve ARI rating.

Cooling Performance with Air Handlers and Furnaces 18, 24, 30

Outdoor Model	Indoor Model		Variable Speed Furnace	Cooling				Heating					Refrigerant Connection				Refrigerant Line Size		Indoor Metering Device		
	Piston or Field Installed TXV	Factory Installed TXV		SEER	EER	Rated ARI Capacity ¹	Rated Sensible Capacity	HSPF	47°		17°		CFM	Outdoor		Indoor		Suction	Liquid	Req'd Indoor ² Orifice	Optional Field Installed Orifice
									Btuh	COP	Btuh	COP		Suction	Liquid	Suction	Liquid				
2HP13**18P	E(C,H,M,U)1P36B+TXV	E(C,H,M,U)2T36B	CG80*C***V12B	14.00	13.00	19,000	15,000	7.7	17,600	3.00	11,500	1.90	650	3/4	3/8	3/4	3/8	3/4	3/8	---	H2TXV01
	E(C,H,M,U)1P36B+TXV	E(C,H,M,U)2T36B	CG95*C***V12B	14.00	13.00	19,000	15,000	7.7	17,600	3.00	11,500	1.90	650	3/4	3/8	3/4	3/8	3/4	3/8	---	H2TXV01
	RBCS2M18C****P	---	---	13.00	12.50	18,000	14,200	7.7	17,000	3.50	8,800	2.20	650	3/4	3/8	3/4	3/8	3/4	3/8	.055	H2TXV01
	RBCS2M18C****P+TXV	---	---	13.00	12.50	18,000	14,200	7.7	17,000	3.50	9,700	1.86	650	3/4	3/8	3/4	3/8	3/4	3/8	---	H2TXV01
	RBCS2M18C****T	---	---	13.00	12.50	18,000	14,200	7.7	17,000	3.50	9,700	1.86	650	3/4	3/8	3/4	3/8	3/4	3/8	---	H2TXV01
	RBCS2M24C****P+TXV	---	---	13.00	12.50	18,000	14,200	7.7	17,000	3.50	9,700	1.86	650	3/4	3/8	3/4	3/8	3/4	3/8	---	H2TXV01
	RBCS2M24C****T	---	---	13.00	12.50	18,000	14,200	7.7	17,000	3.50	9,700	1.86	650	3/4	3/8	3/4	3/8	3/4	3/8	---	H2TXV01
RBCS2M24V****P	---	---	14.00	13.50	18,200	14,400	8.0	16,800	3.70	8,500	2.20	650	3/4	3/8	3/4	3/8	3/4	3/8	.055	H2TXV01	
2HP13**24P	E(C,H,M,U)1P36B+TXV	E(C,H,M,U)2T36B	CG80*C***V12B	14.00	12.50	24,400	19,700	7.7	22,000	3.00	13,000	2.30	850	3/4	3/8	3/4	3/8	3/4	3/8	---	H2TXV01
	E(C,H,M,U)1P36B+TXV	E(C,H,M,U)2T36B	CG80*C***V14B	14.00	12.50	24,400	19,700	7.7	22,000	3.00	13,000	2.30	850	3/4	3/8	3/4	3/8	3/4	3/8	---	H2TXV01
	E(C,H,M,U)1P36B+TXV	E(C,H,M,U)2T36B	CG95*C***V12B	14.00	12.00	24,400	19,700	7.7	22,000	3.00	13,000	2.30	850	3/4	3/8	3/4	3/8	3/4	3/8	---	H2TXV01
	E(C,H,M,U)1P36B+TXV	E(C,H,M,U)2T36B	CG95*C***V14B	14.00	12.00	24,400	19,700	7.7	22,000	3.00	13,000	2.30	850	3/4	3/8	3/4	3/8	3/4	3/8	---	H2TXV01
	RBCS2M24C****P	---	---	13.00	11.50	24,000	19,700	7.7	21,400	3.20	13,400	2.20	850	3/4	3/8	3/4	3/8	3/4	3/8	.063	H2TXV01
	RBCS2M24C****P+TXV	---	---	13.00	11.50	24,000	19,700	7.7	21,400	3.34	13,400	2.22	850	3/4	3/8	3/4	3/8	3/4	3/8	---	H2TXV01
	RBCS2M24C****T	---	---	13.00	11.50	24,000	19,700	7.7	21,400	3.34	13,400	2.22	850	3/4	3/8	3/4	3/8	3/4	3/8	---	H2TXV01
RBCS2M24V****P	---	---	14.00	12.50	24,400	19,700	8.0	21,000	3.50	13,000	2.30	850	3/4	3/8	3/4	3/8	3/4	3/8	.063	H2TXV01	
2HP13**30P	E(C,H,M,U)1P36B+TXV	E(C,H,M,U)2T36B	CG80*C***V12B	14.00	12.00	29,000	23,800	7.7	25,200	3.50	15,500	2.20	1085	3/4	3/8	3/4	3/8	3/4	3/8	---	H2TXV01
	E(C,H,M,U)1P36B+TXV	E(C,H,M,U)2T36B	CG80*C***V14B	14.00	12.00	29,000	23,800	7.7	25,200	3.50	15,500	2.20	1085	3/4	3/8	3/4	3/8	3/4	3/8	---	H2TXV01
	E(C,H,M,U)1P36B+TXV	E(C,H,M,U)2T36B	CG95*C***V12B	14.00	11.50	29,000	23,800	7.7	25,200	3.50	15,500	2.20	1085	3/4	3/8	3/4	3/8	3/4	3/8	---	H2TXV01
	E(C,H,M,U)1P36B+TXV	E(C,H,M,U)2T36B	CG95*C***V14B	14.00	11.50	29,000	23,800	7.7	25,200	3.50	15,500	2.20	1085	3/4	3/8	3/4	3/8	3/4	3/8	---	H2TXV01
	RBCS2M30C****P	---	---	13.00	11.00	28,000	21,700	7.7	27,000	3.40	15,200	2.20	1050	3/4	3/8	3/4	3/8	3/4	3/8	.068	H2TXV01
	RBCS2M30C****P+TXV	---	---	13.00	11.00	28,000	21,700	7.7	27,000	3.40	15,200	2.04	1050	3/4	3/8	3/4	3/8	3/4	3/8	---	H2TXV01
	RBCS2M30C****T	---	---	13.00	11.00	28,000	21,700	7.7	27,000	3.40	15,200	2.04	1050	3/4	3/8	3/4	3/8	3/4	3/8	---	H2TXV01
RBCS2M36V****P	---	---	14.00	12.00	28,400	22,000	8.0	26,600	3.60	15,000	2.20	1050	3/4	3/8	3/4	3/8	3/4	3/8	.068	H2TXV01	

** - B, L, BC, LC
* - B, L

¹ Certified in accordance with Unitary Air Conditioner Certification Program, which is based on ARI Standard 210/240.
² Required to achieve ARI rating.

A blower time delay is required to achieve ARI rating.

Cooling Performance with Air Handlers and Furnaces 36, 42, 48, 60

Outdoor Model	Indoor Model		Variable Speed Furnace	Cooling				Heating					Refrigerant Connection				Refrigerant Line Size		Indoor Metering Device		
	Piston or Field Installed TXV	Factory Installed TXV		SEER	EER	Rated ARI Capacity ¹	Rated Sensible Capacity	HSPF	47°		17°		CFM	Outdoor		Indoor		Suction	Liquid	Req'd Indoor ² Orifice	Optional Field Installed Orifice
									Btuh	COP	Btuh	COP		Suction	Liquid	Suction	Liquid				
2HP13**36P	E(C,H,M,U)1P43B	E(C,H,M,U)2T43B	CG80*C***V12B	14.00	12.00	35,000	25,800	7.7	34,400	3.10	21,200	2.10	1250	3/4	3/8	7/8	3/8	3/4	3/8	.076	H2TXV01
	E(C,H,M,U)1P43B	E(C,H,M,U)2T43B	CG80*C***V14B	14.00	12.00	35,000	25,800	7.7	34,400	3.10	21,200	2.10	1250	3/4	3/8	7/8	3/8	3/4	3/8	.076	H2TXV01
	E(C,H,M,U)1P43B	E(C,H,M,U)2T43B	CG95*C***V12B	14.00	12.00	35,000	25,800	7.7	34,400	3.10	21,200	2.10	1250	3/4	3/8	7/8	3/8	3/4	3/8	.076	H2TXV01
	E(C,H,M,U)1P43B	E(C,H,M,U)2T43B	CG95*C***V14B	14.00	12.00	35,000	25,800	7.7	34,400	3.10	21,200	2.10	1250	3/4	3/8	7/8	3/8	3/4	3/8	.076	H2TXV01
	RBCS2M36C****P	---	---	13.00	11.00	35,000	25,800	7.7	34,600	3.30	19,400	2.20	1250	3/4	3/8	3/4	3/8	7/8	3/8	.076	H2TXV01
	RBCS2M36C****P+TXV	---	---	13.00	11.50	35,000	25,800	7.7	34,600	3.30	20,200	2.22	1250	3/4	3/8	3/4	3/8	3/4	3/8	---	H2TXV01
	RBCS2M36C****T	---	---	13.00	11.50	35,000	25,800	7.7	34,600	3.30	20,200	2.22	1250	3/4	3/8	3/4	3/8	3/4	3/8	---	H2TXV01
RBCS2M36V****P	---	---	14.00	12.00	35,400	26,000	7.9	34,000	3.40	19,200	2.30	1250	3/4	3/8	3/4	3/8	7/8	3/8	.076	H2TXV01	
2HP13**42P	E(C,H,U)1P49C	E(C,H,U)2T49C	CG80*C***V20C	14.00	13.00	40,000	30,000	7.7	37,400	3.10	21,400	2.40	1450	7/8	3/8	7/8	3/8	7/8	3/8	.076	H2TXV02
	E(C,H,U)1P49C	E(C,H,U)2T49C	CG95*C***V16C	14.00	12.50	40,000	30,000	7.7	37,400	3.10	21,400	2.40	1450	7/8	3/8	7/8	3/8	7/8	3/8	.076	H2TXV02
	RBCS2M42C****P	---	---	13.00	11.00	40,000	30,000	7.7	38,000	3.20	22,600	2.20	1450	7/8	3/8	7/8	3/8	7/8	3/8	.076	H2TXV02
	RBCS2M42C****P+TXV	---	---	13.00	12.00	40,000	30,000	7.7	38,000	3.20	22,600	3.32	1450	7/8	3/8	7/8	3/8	7/8	3/8	---	H2TXV02
	RBCS2M42C****T	---	---	13.00	12.00	40,000	30,000	7.7	38,000	3.20	22,600	3.32	1450	7/8	3/8	7/8	3/8	7/8	3/8	---	H2TXV02
	RBCS2M42V****P	---	---	14.00	12.00	40,000	30,000	8.0	37,400	3.40	21,600	2.40	1450	7/8	3/8	7/8	3/8	7/8	3/8	.076	H2TXV02
2HP13**48P	E(C,H,U)1P49C	E(C,H,U)2T49C	CG80*C***V20C	13.50	12.00	46,000	34,500	7.7	44,500	3.00	28,800	2.30	1650	7/8	3/8	7/8	3/8	7/8	3/8	.082	H2TXV02
	RBCS2M48C****P	---	---	13.00	11.00	45,000	33,700	7.7	43,500	3.20	27,000	2.20	1650	7/8	3/8	7/8	3/8	7/8	3/8	.082	H2TXV02
	RBCS2M48C****P+TXV	---	---	13.00	11.50	45,000	33,700	7.7	43,500	3.20	27,400	2.50	1650	7/8	3/8	7/8	3/8	7/8	3/8	---	H2TXV02
	RBCS2M48C****T	---	---	13.00	11.50	45,000	33,700	7.7	43,500	3.20	27,400	2.50	1650	7/8	3/8	7/8	3/8	7/8	3/8	---	H2TXV02
	RBCS2M48V****P	---	---	14.00	12.00	45,500	34,100	8.0	42,500	3.30	26,800	2.60	1650	7/8	3/8	7/8	3/8	7/8	3/8	.082	H2TXV02
2HP13**60P	E(C,H,U)1P62C	E(C,H,U)2T62C	CG80*C***V20C	13.50	12.00	56,000	40,900	7.7	53,500	3.46	31,600	2.60	1950	7/8	3/8	7/8	3/8	1-1/8	3/8	.098	H2TXV02
	RBCS2M60C****P	---	---	13.00	11.00	55,500	40,500	7.7	53,500	3.20	31,000	2.20	1950	7/8	3/8	7/8	3/8	1-1/8	3/8	.098	H2TXV02
	RBCS2M60C****P+TXV	---	---	13.00	11.50	55,500	40,500	7.7	53,500	3.20	31,800	2.56	1950	7/8	3/8	7/8	3/8	1-1/8	3/8	---	H2TXV02
	RBCS2M60V****P	---	---	13.25	11.50	55,500	40,500	8.0	53,000	3.30	31,000	2.50	1950	7/8	3/8	7/8	3/8	1-1/8	3/8	0.098	H2TXV02

** - B, L, BC, LC
* - B, L

¹ Certified in accordance with Unitary Air Conditioner Certification Program, which is based on ARI Standard 210/240.

² Required to achieve ARI rating.

A blower time delay is required to achieve ARI rating.

Cooling Performance with Extended Ratings

Outdoor Model	Indoor Model Piston or Field Installed TXV	Indoor Temp DB/WB °F	Outdoor Temp - DB°F														
			65			82			95			105			115		
			Btuh	S/T	kW	Btuh	S/T	kW	Btuh	S/T	kW	Btuh	S/T	kW	Btuh	S/T	kW
2HP13**18P	RBCS2M18C ****p	85/72	20,700	0.65	1.23	19,800	.69	1.43	19,100	.72	1.51	18,300	.74	1.58	17,000	.75	1.64
		80/67	19,400	0.67	1.19	18,500	.72	1.37	18,000	.74	1.44	17,100	.77	1.50	15,800	.77	1.55
		75/63	18,100	0.69	1.16	17,200	.75	1.31	16,900	.76	1.37	15,900	.80	1.42	14,600	.79	1.47
		75/57	16,900	1.00	1.17	16,500	1.00	1.34	16,000	1.00	1.41	15,200	1.00	1.47	14,100	1.00	1.52
2HP13**24P	RBCS2M24C ****p	85/72	27,400	0.65	1.80	26,100	.69	2.06	25,500	.72	2.17	24,200	.74	2.27	22,400	.75	2.35
		80/67	25,800	0.67	1.73	24,600	.72	1.98	24,000	.74	2.08	22,800	.77	2.17	21,200	.77	2.24
		75/63	24,200	0.70	1.65	23,100	.74	1.89	22,500	.76	1.99	21,400	.80	2.07	20,000	.80	2.14
		75/57	22,400	1.00	1.69	21,900	1.00	1.94	21,400	1.00	2.04	20,300	1.00	2.12	18,900	1.00	2.20
2HP13**30P	RBCS2M30C ****p	85/72	32,000	0.68	2.20	30,500	.72	2.52	29,700	.75	2.65	28,200	.78	2.76	26,200	.78	2.86
		80/67	30,100	0.70	2.12	28,700	.75	2.43	28,000	.77	2.55	26,600	.80	2.66	24,600	.81	2.75
		75/63	28,200	0.72	2.05	26,900	.77	2.33	26,300	.79	2.45	25,000	.82	2.55	23,000	.83	2.64
		75/57	26,200	1.00	2.08	25,500	1.00	2.38	24,900	1.00	2.50	23,700	1.00	2.60	21,900	1.00	2.69
2HP13**36P	RBCS2M36C ****p	85/72	39,900	0.65	2.75	38,100	.70	3.15	37,200	.72	3.31	35,300	.75	3.45	32,700	.75	3.57
		80/67	37,600	0.67	2.65	35,900	.72	3.03	35,000	.74	3.18	33,300	.77	3.31	30,800	.77	3.42
		75/63	35,300	0.70	2.56	33,700	.73	2.90	32,800	.76	3.05	31,300	.79	3.17	28,900	.80	3.28
		75/57	32,700	1.00	2.60	32,000	1.00	2.97	31,200	1.00	3.12	29,600	1.00	3.24	27,400	1.00	3.36
2HP13*42P	RBCS2M42C ****p	85/72	45,600	0.66	3.20	43,500	.71	3.60	42,500	.73	3.77	40,300	.76	3.91	37,400	.76	4.03
		80/67	43,000	0.68	3.12	41,000	.73	3.49	40,000	.75	3.64	38,000	.78	3.77	35,200	.78	3.88
		75/63	40,400	0.71	3.04	38,500	.74	3.38	37,500	.77	3.51	35,700	.80	3.63	33,000	.81	3.73
		75/57	37,400	1.00	3.06	36,500	1.00	3.42	35,600	1.00	3.57	33,800	1.00	3.69	31,300	1.00	3.80
2HP13*48P	RBCS2M48C ****p	85/72	51,400	0.66	3.56	49,000	.71	4.05	47,800	.73	4.25	45,400	.76	4.42	42,000	.76	4.57
		80/67	48,400	0.68	3.43	46,100	.73	3.90	45,000	.75	4.09	42,700	.78	4.25	39,600	.78	4.39
		75/63	45,400	0.71	3.31	43,200	.74	3.75	42,200	.77	3.93	40,000	.80	4.09	37,200	.81	4.22
		75/57	42,100	1.00	3.37	41,000	1.00	3.82	40,100	1.00	4.01	38,000	1.00	4.17	35,200	1.00	4.31
2HP13*60P	RBCS2M60C ****p	85/72	63,300	0.65	4.41	60,400	.69	5.00	58,900	.71	5.24	56,000	.74	5.45	51,800	.74	5.63
		80/67	59,600	0.67	4.23	59,900	.72	4.78	55,500	.74	5.01	52,700	.77	5.20	48,800	.77	5.37
		75/63	55,900	0.70	4.05	53,400	.74	4.56	52,100	.77	4.78	49,400	.80	4.96	45,800	.81	5.11
		75/57	51,900	1.00	4.14	50,600	1.00	4.69	49,400	1.00	4.91	46,900	1.00	5.10	43,400	1.00	5.26

** - B, L, BC, LC
* - B, L

A blower time delay is required to achieve ARI rating.
Which is part of these air handler and furnace controls.
Above information is for nominal CFM.

Note: Extended data shown is actual for models listed and typical for all AHRI matches.

Heating Performance with Extended Ratings

The information below is for nominal CFM and 70° indoor dry bulb.

Outdoor Model	Indoor Model		Outdoor Ambient Temperature														
	Piston or Field	Factory Installed		65	60	55	50	47	45	40	35	30	25	20	17	15	10
2HP13***18	RBCS2M18C ****P	RBCS2M18C ****T	Btuh	21,100	20,200	19,300	18,400	17,000	16,200	15,200	14,100	13,150	12,142	11,133	10,500	9,242	8,248
			Kw	1.52	1.50	1.48	1.46	1.42	1.40	1.38	1.35	1.33	1.30	1.28	1.27	1.23	1.21
			COP	3.99	3.95	3.91	3.87	3.50	3.53	3.42	3.07	3.05	2.96	2.83	2.24	2.31	2.27
2HP13**24P	RBCS2M24C ****P	RBCS2M24C ****T	Btuh	26,800	25,500	24,200	22,900	21,400	20,140	18,800	17,800	16,290	14,978	13,667	12,700	11,158	9,860
			Kw	2.11	2.07	2.02	1.98	1.96	1.91	1.87	1.86	1.81	1.79	1.78	1.77	1.70	1.67
			COP	3.80	3.61	3.41	3.22	3.20	2.97	2.81	2.79	2.56	2.41	2.26	2.10	1.96	1.81
2HP13**30P	RBCS2M30C ****P	RBCS2M30C ****T	Btuh	33,900	32,100	30,300	28,500	27,000	25,140	23,400	22,400	20,290	18,612	16,933	15,400	13,625	11,952
			Kw	2.47	2.44	2.42	2.39	2.32	2.30	2.27	2.21	2.18	2.15	2.13	2.12	2.06	2.02
			COP	3.95	3.85	3.74	3.64	3.41	3.33	3.20	2.97	2.89	2.76	2.62	2.12	2.10	2.07
2HP13**36P	RBCS2M36C ****P	RBCS2M36C ****T	Btuh	43,900	41,100	38,300	35,500	34,600	31,420	29,000	28,700	25,220	22,977	20,733	19,800	16,683	14,490
			Kw	3.28	3.23	3.19	3.14	3.07	3.03	2.98	2.92	2.87	2.82	2.77	2.64	2.64	2.58
			COP	3.80	3.73	3.65	3.58	3.30	3.26	3.15	2.88	2.84	2.71	2.59	2.19	2.17	2.10
2HP13*42P	RBCS2M42C ****P	RBCS2M42C ****T	Btuh	47,000	45,200	43,400	41,600	38,000	36,560	34,400	31,500	29,710	27,488	25,267	22,700	20,708	18,473
			Kw	3.71	3.64	3.57	3.50	3.48	3.40	3.34	3.33	3.25	3.19	3.13	2.71	2.65	2.48
			COP	3.74	3.64	3.53	3.43	3.20	3.12	2.99	2.86	2.73	2.60	2.50	2.46	2.34	2.25
2HP13*48P	RBCS2M48C ****P	RBCS2M48C ****T	Btuh	55,200	51,800	48,400	45,000	43,500	39,720	36,700	36,100	31,870	29,052	28,200	27,400	22,491	19,888
			Kw	4.28	4.19	4.09	4.00	3.98	3.87	3.79	3.79	3.67	3.60	3.53	3.16	3.09	2.93
			COP	3.80	3.62	3.44	3.25	3.07	3.06	2.82	2.79	2.57	2.42	2.27	2.21	2.00	1.86
2HP13*60P	RBCS2M60C ****P	RBCS2M60C ****T	Btuh	66,200	63,600	61,000	58,400	53,500	51,360	48,300	44,400	41,760	38,630	35,500	31,900	29,083	25,935
			Kw	5.25	5.15	5.05	4.94	4.90	4.79	4.70	4.67	4.55	4.46	4.38	3.66	3.57	3.30
			COP	3.68	3.62	3.56	3.50	3.20	3.18	3.07	2.78	2.76	2.64	2.57	2.55	2.34	2.22

** - B, L, BC, LC
* - B, L

Accessories

Description	Where Used	Catalog No.
Hard Start Kit	2HP13**18, 24, 30, 36, - 2HP13*42, 48	12W59
High Pressure Kit	2HP13**18, 24, 30, 36, - 2HP13*42, 48	14W09
Low Pressure Kit	Factory Installed on all models	-----
Short Cycle Protection	Factory Installed on all models	-----
Crankcase Heater	2HP13**18, 24, 30, 36 - 2HP13*42,48	14W05
Crankcase Heater	2HP13*60	14W04
Sound Blanket	2HP13**18, 24, 30	14W02
	2HP13**36 - 2HP*42, 48	14W00
	2HP*60	14W01
Outdoor Thermostat	2HP13**18, 24, 30, 36, - 2HP13*42, 48, 60	17W03
Fossil Fuel Kit	2HP13**18, 24, 30, 36, - 2HP13*42, 48, 60	17W02
TXV	2HP13**18, 24, 30, 36	H2TXV01
	2HP13*42, 48, 60	H2TXV02

All specifications and illustrations subject to change without notice and without incurring obligations.

Ducone™
**AIR CONDITIONING
 AND HEATING**

www.ducanehvac.com
 1-800-448-5872

