

Split System Heat Pump

14
seer

2HP14 Features and Benefits

- Durable scroll compressors, with internal pressure relief valves and inherent thermal protection
- High-quality condenser coil with copper tubing and enhanced louvered fin for maximum heat transfer capacity
- Top discharge directs hot air and sound away from living area and shrubbery
- All units run tested
- Available with louvered panel or wire guard coil protection option
- Easy access to electrical panels, pre-wired for easy hook-up
- Hinged control panel allows simple access to internal components
- Bi-directional liquid line filter drier factory installed
- Discharge muffler for quiet operation
- Integrated LED diagnostics is a reliable, solid state time / temperature defrost control, with field selectable 30/60/90 minute intervals and is Quiet ShiftTM capable to reduce noise
- Low pressure switch for loss of charge protection (factory installed)
- Short cycle protection (factory installed)
- All units ETL, ETLC approved and ARI listed
- Charged for 15 feet of interconnecting tubing
- 10 year limited parts warranty available (5 year compressor). See limited warranty document for details.



L Model



B Model

Model Number Guide

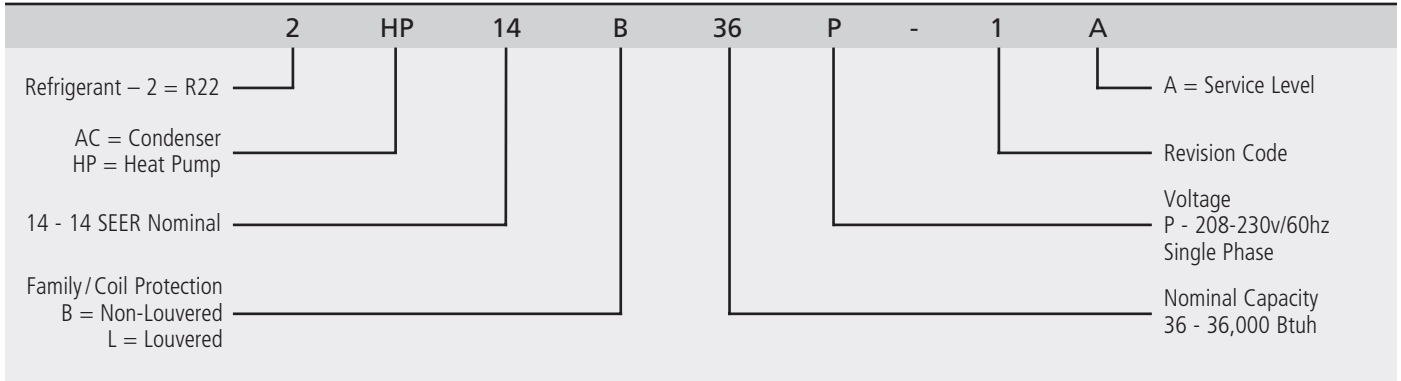

Electrical and Physical Data

Model	Voltage/ Hz/ Phase	Voltage Range	Min. Circuit Amp.	Maximum Over Current Device (amps)	Compressor		Fan Motor			Refrig. Charge (oz.)*	Weight (lbs.) Wire Guard/ Louvered
					Rated Load (Amps)	Locked Rotor (Amps)	Full Load Amps	Rated HP	Nom. RPM		
2HP14*18P	208-230/60/1	197 - 253	11.1	20	8.3	41	0.7	1/10	1075	139	162/174
2HP14*24P	208-230/60/1	197 - 253	14.6	25	10.3	56	0.7	1/10	1075	131	175/187
2HP14*30P	208-230/60/1	197 - 253	16.0	25	12.2	61	0.8	1/5	1075	160	187/200
2HP14*36P	208-230/60/1	197 - 253	18.4	30	13.5	73	0.8	1/5	1075	177	195/208
2HP14*42P	208-230/60/1	197 - 253	22.2	35	16.5	95	1.4	1/4	1075	188	222/239
2HP14*48P	208-230/60/1	197 - 253	23.7	40	18.0	104	1.4	1/4	1075	273	224/241
2HP14*60P	208-230/60/1	197 - 253	26.0	40	19.2	137	2.0	1/3	1075	252	275/292

* = B, L * Charge amount is with 15 feet of line set. Adjust per installation instructions.

Dimensions (in.) and Sound Ratings

Model	Dimensions			B, L Sound Rating (dBA)
	A - width (in.)	B - width (in.)	C - width (in.)	
2HP14*18P	30	30	25.75	78
2HP14*24P	30	30	25.75	79
2HP14*30P	30	30	29.75	79
2HP14*36P	30	30	29.75	79
2HP14*42P	30	30	41.75	78
2HP14*48P	30	30	41.75	78
2HP14*60P	30	30	41.75	78

* = B, L

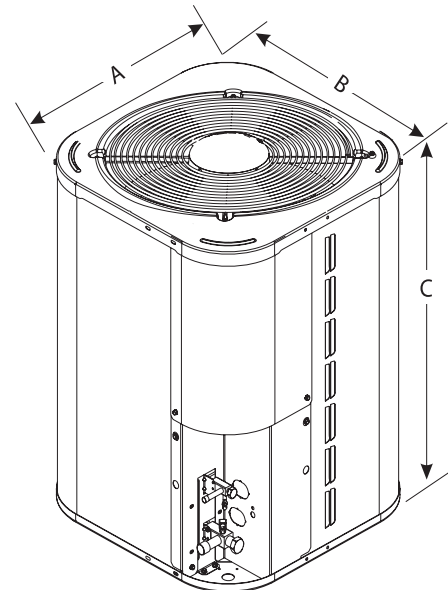

Cooling Performance with Evaporator Coils

Outdoor Model	Indoor Model		Cooling				Heating					Refrigerant Connection		Refrigerant Line Size		Indoor Metering Device				
	Piston or Field Installed TXV	Factory Installed TXV	SEER	EER	Rated ARI Capacity ¹	Rated Sensible Capacity	HSPF	47°		17°		CFM	Outdoor		Indoor		Suction	Liquid	Req'd Indoor ² Orifice	Optional Field Installed Orifice
								Btuh	COP	Btuh	COP		Suction	Liquid	Suction	Liquid				
2HP14*24P	E(C,H,M,U)2T29A	---	14.00	12.50	24,000	18,500	8.20	22,400	3.40	14,400	2.24	850	3/4	3/8	3/4	3/8	3/4	3/8	---	H2TXV01
2HP14*30P	E(C,H,M,U)1P36(A,B,C)+TXV	---	13.50	12.00	28,400	23,000	7.70	26,000	2.94	18,400	2.26	1050	3/4	3/8	3/4	3/8	3/4	3/8	---	H2TXV01
	E(C,H,M,U)1P43B+TXV	---	13.50	12.00	29,000	23,800	7.70	26,000	2.94	18,200	2.24	1050	3/4	3/8	7/8	3/8	3/4	3/8	---	H2TXV01
	E(C,H,M,U)2T36(A,B,C)	---	13.50	12.00	28,400	23,000	7.70	26,000	2.94	18,400	2.26	1050	3/4	3/8	3/4	3/8	3/4	3/8	---	H2TXV01
	E(C,H,M,U)2T43B	---	13.50	13.00	29,000	23,800	7.70	26,000	2.94	18,200	2.24	1050	3/4	3/8	7/8	3/8	3/4	3/8	---	H2TXV01
	E(C,M,U)1P48(B,C)+TXV	---	13.50	12.00	28,800	23,500	7.70	26,000	2.90	18,000	2.22	1050	3/4	3/8	7/8	3/8	3/4	3/8	---	H2TXV01
	E(C,H,M,U)2T48(B,C)	---	13.50	12.00	28,800	23,500	7.70	26,000	2.90	18,000	2.22	1050	3/4	3/8	7/8	3/8	3/4	3/8	---	H2TXV01
2HP14*48P	E(C,H,U)1P49C+TXV	E(C,H,U)2T49C	14.00	11.50	47,000	39,200	8.20	45,500	3.60	26,400	2.18	1700	7/8	3/8	7/8	3/8	7/8	3/8	---	H2TXV02
	E(C,H,U)1P62D+TXV	E(C,H,U)2T62D	14.00	11.50	47,000	39,200	8.20	45,500	3.60	26,400	2.20	1700	7/8	3/8	7/8	3/8	7/8	3/8	---	H2TXV02
2HP14*60P	E(C,H,U)1P62C+TXV	E(C,H,U)2T62C	13.00	12.00	53,000	43,900	7.70	52,000	3.30	32,000	2.30	1950	7/8	3/8	7/8	3/8	1-1/8	3/8	---	H2TXV02
	E(C,H,U)1P62D+TXV	E(C,H,U)2T62D	13.00	12.00	53,000	43,900	7.70	52,000	3.30	32,000	2.30	1950	7/8	3/8	7/8	3/8	1-1/8	3/8	---	H2TXV02

¹ Certified in accordance with Unitary Air Conditioner Certification Program, which is based on ARI Standard 210/240.

² Required to achieve ARI rating.

A blower time delay is required to achieve ARI rating.

Cooling Performance with Air Handlers and Furnaces 18, 24, 30

Outdoor Model	Indoor Model		Furnace	Cooling				Heating					Refrigerant Connection		Refrigerant Line Size		Indoor Metering Device				
	Piston or Field Installed TXV	Factory Installed TXV		SEER	EER	Rated ARI	Rated Sensible Capacity	HSPF	47°		17°		CFM	Outdoor		Indoor		Suction	Liquid	Req'd Indoor ² Orifice	Optional Field Installed Orifice
									Btuh	COP	Btuh	COP		Suction	Liquid	Suction	Liquid				
2HP14*18P	E(C,H,M,U)1P36B+TXV	E(C,H,M,U)2T36B	CG80°C***V12B	15.00	13.50	19,000	15,200	8.00	17,300	3.64	9,500	2.20	650	3/4	3/8	3/4	3/8	3/4	3/8	---	H2TXV01
	E(C,H,M,U)1P36B+TXV	E(C,H,M,U)2T36B	CG95°C***V12B	15.00	13.50	19,000	15,200	7.70	17,300	3.64	9,500	2.20	650	3/4	3/8	3/4	3/8	3/4	3/8	---	H2TXV01
	RBCS2M18C****P+TXV	---	---	14.00	12.50	19,000	15,200	7.70	17,300	3.50	9,500	2.12	650	3/4	3/8	3/4	3/8	3/4	3/8	---	H2TXV01
	RBCS2M18C****T	---	---	14.00	12.50	19,000	15,200	7.70	17,300	3.50	9,500	2.12	650	3/4	3/8	3/4	3/8	3/4	3/8	---	H2TXV01
	RBCS2M24V****P+TXV	---	---	15.00	14.00	19,000	15,200	8.10	17,000	3.70	9,200	2.10	650	3/4	3/8	3/4	3/8	3/4	3/8	---	H2TXV01
2HP14*24P	E(C,H,M,U)1P36B+TXV	E(C,H,M,U)2T36B	CG80°C***V12B	14.00	12.50	24,000	18,500	8.20	22,400	3.40	14,200	2.24	850	3/4	3/8	3/4	3/8	3/4	3/8	---	H2TXV01
	E(C,H,M,U)1P36B+TXV	E(C,H,M,U)2T36B	CG80°C***V14B	14.00	12.50	24,000	18,500	8.20	22,400	3.40	14,200	2.24	850	3/4	3/8	3/4	3/8	3/4	3/8	---	H2TXV01
	E(C,H,M,U)1P36B+TXV	E(C,H,M,U)2T36B	CG95°C***V12B	14.00	12.50	24,000	18,500	8.20	22,400	3.40	14,400	2.24	850	3/4	3/8	3/4	3/8	3/4	3/8	---	H2TXV01
	E(C,H,M,U)1P36B+TXV	E(C,H,M,U)2T36B	CG95°C***V14B	14.00	12.50	24,000	18,500	8.20	22,400	3.40	14,400	2.24	850	3/4	3/8	3/4	3/8	3/4	3/8	---	H2TXV01
	RBCS2M24C****P+TXV	---	---	14.00	12.35	25,000	19,300	8.20	21,800	3.30	14,200	2.18	850	3/4	3/8	3/4	3/8	3/4	3/8	---	H2TXV01
	RBCS2M24C****T	---	---	14.00	12.35	25,000	19,300	8.20	21,800	3.30	14,200	2.18	850	3/4	3/8	3/4	3/8	3/4	3/8	---	H2TXV01
	RBCS2M24V****P+TXV	---	---	15.00	13.00	25,000	19,300	8.30	21,600	3.50	13,800	2.20	850	3/4	3/8	3/4	3/8	3/4	3/8	---	H2TXV01
2HP14*30P	E(C,H,M,U)1P36B+TXV	E(C,H,M,U)2T36B	CG80°C***V12B	14.00	12.50	29,000	23,800	8.20	26,000	3.48	18,400	2.26	1050	3/4	3/8	3/4	3/8	3/4	3/8	---	H2TXV01
	E(C,H,M,U)1P36B+TXV	E(C,H,M,U)2T36B	CG80°C***V14B	14.00	12.50	29,000	23,800	8.20	26,000	3.48	18,400	2.26	1050	3/4	3/8	3/4	3/8	3/4	3/8	---	H2TXV01
	E(C,H,M,U)1P36B+TXV	E(C,H,M,U)2T36B	CG95°C***V12B	14.00	12.50	29,000	23,800	8.20	26,000	3.48	18,400	2.26	1050	3/4	3/8	3/4	3/8	3/4	3/8	---	H2TXV01
	E(C,H,M,U)1P36B+TXV	E(C,H,M,U)2T36B	CG95°C***V14B	14.00	12.50	29,000	23,800	8.20	26,000	3.48	18,400	2.26	1050	3/4	3/8	3/4	3/8	3/4	3/8	---	H2TXV01
	E(C,H,M,U)1P43B+TXV	E(C,H,M,U)2T43B	CG80°C***V12B	14.50	13.00	29,000	23,800	8.20	26,000	3.50	18,200	2.24	1050	3/4	3/8	7/8	3/8	3/4	3/8	---	H2TXV01
	E(C,H,M,U)1P43B+TXV	E(C,H,M,U)2T43B	CG80°C***V14B	14.50	13.00	29,000	23,800	8.20	26,000	3.50	18,200	2.24	1050	3/4	3/8	7/8	3/8	3/4	3/8	---	H2TXV01
	E(C,H,M,U)1P43B+TXV	E(C,H,M,U)2T43B	CG95°C***V12B	14.50	13.00	29,000	23,800	8.20	26,000	3.50	18,200	2.24	1050	3/4	3/8	7/8	3/8	3/4	3/8	---	H2TXV01
	E(C,H,M,U)1P43B+TXV	E(C,H,M,U)2T43B	CG95°C***V14B	14.50	13.00	29,000	23,800	8.20	26,000	3.50	18,200	2.24	1050	3/4	3/8	7/8	3/8	3/4	3/8	---	H2TXV01
	E(C,M,U)1P48B+TXV	E(C,M,U)2T48B	CG80°C***V12B	14.50	13.00	29,000	23,800	8.20	26,000	3.46	18,000	2.22	1050	3/4	3/8	7/8	3/8	3/4	3/8	---	H2TXV01
	E(C,M,U)1P48B+TXV	E(C,M,U)2T48B	CG80°C***V14B	14.50	13.00	29,000	23,800	8.20	26,000	3.46	18,000	2.22	1050	3/4	3/8	7/8	3/8	3/4	3/8	---	H2TXV01
	E(C,M,U)1P48B+TXV	E(C,M,U)2T48B	CG95°C***V12B	14.50	13.00	29,000	23,800	8.20	26,000	3.46	18,000	2.22	1050	3/4	3/8	7/8	3/8	3/4	3/8	---	H2TXV01
	E(C,M,U)1P48B+TXV	E(C,M,U)2T48B	CG95°C***V14B	14.50	13.00	29,000	23,800	8.20	26,000	3.46	18,000	2.22	1050	3/4	3/8	7/8	3/8	3/4	3/8	---	H2TXV01
	RBCS2M30C****P+TXV	---	---	14.00	12.50	28,400	23,000	8.20	26,000	3.44	18,400	2.26	1050	3/4	3/8	3/4	3/8	3/4	3/8	---	H2TXV01
	RBCS2M30C****T	---	---	14.00	12.50	28,400	23,000	8.20	26,000	3.44	18,400	2.26	1050	3/4	3/8	3/4	3/8	3/4	3/8	---	H2TXV01
	RBCS2M36V****P+TXV	---	---	15.00	13.00	28,600	23,300	8.30	26,000	3.60	15,300	2.30	1050	3/4	3/8	3/4	3/8	3/4	3/8	---	H2TXV01

Cooling Performance with Air Handlers and Furnaces 36, 42, 48, 60

Outdoor Model	Indoor Model		Furnace	Cooling				Heating					Refrigerant Connection		Refrigerant Line Size		Indoor Metering Device				
	Piston or Field Installed TXV	Factory Installed TXV		SEER	EER	Rated ARI	Rated Sensible Capacity	HSPF	47°		17°		CFM	Outdoor		Suction	Liquid	Req'd Indoor ² Orifice	Optional Field Installed Orifice		
									Btuh	COP	Btuh	COP		Suction	Liquid						
2HP14*36P	E(C,H,M,U)1P36B+TXV	E(C,H,M,U)2T36B	CG80*C***V12B	14.50	12.50	35,000	28,000	8.20	33,000	3.46	20,200	2.38	1250	3/4	3/8	3/4	3/8	3/4	3/8	---	H2TXV01
	E(C,H,M,U)1P36B+TXV	E(C,H,M,U)2T36B	CG80*C***V14B	14.50	12.50	35,000	28,000	8.20	33,000	3.46	20,200	2.38	1250	3/4	3/8	3/4	3/8	3/4	3/8	---	H2TXV01
	E(C,H,M,U)1P36B+TXV	E(C,H,M,U)2T36B	CG95*C***V12B	14.50	12.50	35,000	28,000	8.20	33,000	3.46	20,200	2.38	1250	3/4	3/8	3/4	3/8	3/4	3/8	---	H2TXV01
	E(C,H,M,U)1P36B+TXV	E(C,H,M,U)2T36B	CG95*C***V14B	14.50	12.50	35,000	28,000	8.20	33,000	3.46	20,200	2.38	1250	3/4	3/8	3/4	3/8	3/4	3/8	---	H2TXV01
	E(C,H,M,U)1P43B+TXV	E(C,H,M,U)2T43B	CG80*C***V12B	14.50	12.50	35,000	28,000	8.20	32,800	3.46	19,800	2.32	1250	3/4	3/8	7/8	3/8	3/4	3/8	---	H2TXV01
	E(C,H,M,U)1P43B+TXV	E(C,H,M,U)2T43B	CG80*C***V14B	14.50	12.50	35,000	28,000	8.20	32,800	3.46	19,800	2.32	1250	3/4	3/8	7/8	3/8	3/4	3/8	---	H2TXV01
	E(C,H,M,U)1P43B+TXV	E(C,H,M,U)2T43B	CG95*C***V12B	14.50	12.50	35,000	28,000	8.20	32,800	3.46	19,800	2.32	1250	3/4	3/8	7/8	3/8	3/4	3/8	---	H2TXV01
	E(C,H,M,U)1P43B+TXV	E(C,H,M,U)2T43B	CG95*C***V14B	14.50	12.50	35,000	28,000	8.20	32,800	3.46	19,800	2.32	1250	3/4	3/8	7/8	3/8	3/4	3/8	---	H2TXV01
	E(C,M,U)1P48B+TXV	E(C,M,U)2T48B	CG80*C***V12B	15.00	12.50	35,000	28,000	8.00	32,400	3.40	19,200	2.20	1250	3/4	3/8	7/8	3/8	3/4	3/8	---	H2TXV01
	E(C,M,U)1P48B+TXV	E(C,M,U)2T48B	CG80*C***V14B	15.00	12.50	35,000	28,000	8.00	32,400	3.40	19,200	2.20	1250	3/4	3/8	7/8	3/8	3/4	3/8	---	H2TXV01
	E(C,M,U)1P48B+TXV	E(C,M,U)2T48B	CG95*C***V12B	15.00	12.50	35,000	28,000	8.00	32,400	3.40	19,200	2.20	1250	3/4	3/8	7/8	3/8	3/4	3/8	---	H2TXV01
	E(C,M,U)1P48B+TXV	E(C,M,U)2T48B	CG95*C***V14B	15.00	12.50	35,000	28,000	8.00	32,400	3.40	19,200	2.20	1250	3/4	3/8	7/8	3/8	3/4	3/8	---	H2TXV01
	RBCS2M36C****P+TXV	---	---	14.00	12.00	35,000	28,000	8.20	33,000	3.40	20,400	2.34	1250	3/4	3/8	3/4	3/8	3/4	3/8	---	H2TXV01
	RBCS2M36C****T	---	---	14.00	12.00	35,000	28,000	8.20	33,000	3.40	20,400	2.34	1250	3/4	3/8	3/4	3/8	3/4	3/8	---	H2TXV01
RBCS2M36V****P+TXV	---	---	15.00	12.50	35,600	28,500	8.50	32,800	3.50	20,000	2.40	1250	3/4	3/8	3/4	3/8	3/4	3/8	---	H2TXV01	
2HP14*42P	E(C,H,M,U)1P43B+TXV	E(C,H,M,U)2T43B	CG80*C***V14B	14.00	12.00	41,000	32,800	8.20	37,400	3.40	23,000	2.30	1450	7/8	3/8	7/8	3/8	7/8	3/8	---	H2TXV02
	E(C,H,M,U)1P43B+TXV	E(C,H,M,U)2T43B	CG95*C***V14B	14.00	12.00	41,000	32,800	8.20	37,400	3.40	23,000	2.30	1450	7/8	3/8	7/8	3/8	7/8	3/8	---	H2TXV02
	E(C,H,U)1P49C+TXV	E(C,H,U)2T49C	CG80*C***V20C	15.00	13.00	42,000	33,800	8.20	37,400	3.40	23,000	2.30	1450	7/8	3/8	7/8	3/8	7/8	3/8	---	H2TXV02
	E(C,H,U)1P49C+TXV	E(C,H,U)2T49C	CG95*C***V16C	15.00	13.00	42,000	33,800	8.20	37,400	3.40	23,000	2.30	1450	7/8	3/8	7/8	3/8	7/8	3/8	---	H2TXV02
	E(C,M,U)1P50C+TXV	E(C,M,U)2T50C	CG80*C***V20C	14.50	12.50	41,000	32,800	8.20	37,000	3.40	22,400	2.30	1450	7/8	3/8	7/8	3/8	7/8	3/8	---	H2TXV02
	E(C,M,U)1P50C+TXV	E(C,M,U)2T50C	CG95*C***V16C	14.50	12.50	41,000	32,800	8.20	37,000	3.40	22,400	2.30	1450	7/8	3/8	7/8	3/8	7/8	3/8	---	H2TXV02
	RBCS2M42C****P+TXV	---	---	14.00	12.00	41,500	33,400	8.20	38,500	3.40	23,800	2.30	1450	7/8	3/8	7/8	3/8	7/8	3/8	---	H2TXV02
	RBCS2M42C****T	---	---	14.00	12.00	41,500	33,400	8.20	38,500	3.40	23,800	2.30	1450	7/8	3/8	7/8	3/8	7/8	3/8	---	H2TXV02
	RBCS2M42V****P+TXV	---	---	14.50	12.50	42,000	33,800	8.20	38,500	3.50	23,400	2.40	1450	7/8	3/8	7/8	3/8	7/8	3/8	---	H2TXV02
2HP14*48P	E(C,H,U)1P49C+TXV	E(C,H,U)2T49C	CG80*C***V20C	14.00	12.00	47,500	39,200	8.20	45,500	3.60	26,400	2.42	1700	7/8	3/8	7/8	3/8	7/8	3/8	---	H2TXV02
	E(C,H,U)1P49C+TXV	E(C,H,U)2T49C	CG95*C***V20C	14.00	12.00	47,500	39,200	8.20	45,500	3.60	26,400	2.42	1700	7/8	3/8	7/8	3/8	7/8	3/8	---	H2TXV02
	RBCS2M60C****P+TXV	---	---	14.00	12.20	47,000	39,200	8.20	45,500	3.60	27,400	2.48	1720	7/8	3/8	7/8	3/8	7/8	3/8	---	H2TXV02
	RBCS2M60C****T+TXV	---	---	14.00	12.20	47,000	39,200	8.20	45,500	3.60	27,400	2.48	1720	7/8	3/8	7/8	3/8	7/8	3/8	---	H2TXV02
RBCS2M60V****P+TXV	---	---	14.75	12.50	47,500	39,200	8.20	45,000	3.70	26,400	2.50	1720	7/8	3/8	7/8	3/8	7/8	3/8	---	H2TXV02	
2HP14*60P	RBCS2M60V****P+TXV	---	14.00	12.00	53,000	43,900	8.20	52,500	3.30	32,000	2.30	1950	7/8	3/8	7/8	3/8	1-1/8	3/8	---	H2TXV02	

Cooling Performance with Extended Ratings

Outdoor Model	Indoor Model Piston or Field Installed TXV	Indoor Temp DB/WB °F	Outdoor Temp - DB°F														
			65			82			95			105			115		
			Btuh	S/T	kW	Btuh	S/T	kW	Btuh	S/T	kW	Btuh	S/T	kW	Btuh	S/T	kW
2HP14*18P	RBCS2M18C ****P+TXV	85/72	21,700	.63	1.32	20,700	.67	1.50	20,200	.69	1.58	19,200	.72	1.64	17,700	.72	1.70
		80/67	20,400	.65	1.27	19,500	.69	1.45	19,000	.71	1.52	18,100	.74	1.58	16,700	.74	1.63
		75/63	18,900	.69	1.23	18,000	.73	1.39	17,600	.76	1.46	16,700	.79	1.52	15,500	.79	1.57
		75/57	18,200	1.00	1.26	17,600	1.00	1.43	17,100	1.00	1.50	16,300	1.00	1.57	15,000	1.00	1.62
2HP14*24P	RBCS2M24C ****P+TXV	85/72	28,500	.65	1.80	27,200	.70	2.06	26,500	.72	2.17	25,200	.75	2.26	23,400	.75	2.34
		80/67	26,900	.67	1.73	25,600	.72	1.98	25,000	.74	2.08	23,800	.77	2.17	22,000	.77	2.25
		75/63	24,900	.72	1.67	23,700	.77	1.90	23,200	.79	2.00	22,000	.82	2.08	20,400	.83	2.16
		75/57	23,900	1.00	1.71	23,000	1.00	1.96	22,500	1.00	2.06	21,400	1.00	2.15	19,800	1.00	2.23
2HP14*30P	RBCS2M30C ****P+TXV	85/72	32,400	.68	1.93	30,900	.72	2.25	30,100	.75	2.38	28,600	.78	2.49	26,500	.78	2.58
		80/67	30,500	.70	1.84	29,100	.75	2.15	28,400	.77	2.27	27,000	.80	2.38	25,000	.81	2.47
		75/63	28,300	.75	1.77	27,000	.80	2.05	26,300	.82	2.17	25,000	.85	2.27	23,200	.86	2.36
		75/57	27,100	1.00	1.82	26,200	1.00	2.13	25,600	1.00	2.25	24,300	1.00	2.36	22,500	1.00	2.45
2HP14*36P	RBCS2M36C ****P+TXV	85/72	39,900	.65	2.49	38,100	.70	2.88	37,200	.72	3.05	35,300	.75	3.18	32,700	.75	3.30
		80/67	37,600	.67	2.39	35,900	.72	2.76	35,000	.74	2.92	33,300	.77	3.05	30,800	.77	3.16
		75/63	34,900	.72	2.29	33,200	.77	2.65	32,400	.79	2.79	30,800	.82	2.92	28,500	.83	3.03
		75/57	33,500	1.00	2.37	32,300	1.00	2.74	31,500	1.00	2.89	30,000	1.00	3.02	27,700	1.00	3.13
2HP14*42P	RBCS2M42C ****P+TXV	85/72	47,400	.66	3.04	45,200	.71	3.43	44,100	.73	3.59	41,900	.76	3.72	38,800	.76	3.84
		80/67	44,600	.68	2.94	42,500	.73	3.31	41,500	.75	3.46	39,400	.78	3.59	36,500	.78	3.70
		75/63	41,300	.73	2.84	39,400	.78	3.19	38,500	.80	3.34	36,500	.83	3.46	33,800	.84	3.57
		75/57	39,700	1.00	2.91	38,300	1.00	3.27	37,400	1.00	3.42	35,500	1.00	3.55	32,900	1.00	3.66
2HP14*48P	RBCS2M60C ****P+TXV	85/72	53,600	.66	3.39	51,100	.71	3.88	49,900	.73	4.08	47,400	.76	4.25	43,900	.76	4.40
		80/67	50,500	.68	3.26	48,200	.73	3.73	47,000	.75	3.92	44,700	.78	4.08	41,400	.78	4.22
		75/63	46,500	.73	3.14	44,600	.78	3.58	43,600	.80	3.76	41,400	.83	3.92	38,300	.84	4.05
		75/57	44,900	1.00	3.23	43,400	1.00	3.69	42,300	1.00	3.88	40,200	1.00	4.04	37,300	1.00	4.18
2HP14*60P	RBCS2M60V ****P+TXV	85/72	60,500	.65	3.79	57,700	.70	4.37	56,300	.72	4.61	53,400	.75	4.81	49,500	.75	4.99
		80/67	57,000	.67	3.64	54,300	.72	4.19	53,000	.74	4.42	50,400	.77	4.61	46,600	.77	4.78
		75/63	52,800	.72	3.49	50,300	.77	4.02	49,100	.79	4.24	46,700	.82	4.42	43,200	.83	4.58
		75/57	50,700	1.00	3.60	48,900	1.00	4.15	47,700	1.00	4.37	45,400	1.00	4.57	41,900	1.00	4.73

Heating Performance with Extended Ratings

The information below is for nominal CFM and 70° indoor dry bulb.

Outdoor Model	Indoor Model		Outdoor Ambient Temperature														
	Piston or Field	Factory Installed		65	60	55	50	47	45	40	35	30	25	20	17	15	10
2HP14*18P	RBCS2M18C ****P+TXV	RBCS2M18C ****T	Btuh	21,700	20,600	19,400	18,100	17,300	16,800	15,600	14,400	11,800	10,900	10,100	9,500	9,100	8,200
			Kw	1.55	1.52	1.49	1.46	1.45	1.44	1.41	1.38	1.37	1.36	1.33	1.31	1.30	1.27
			COP	4.10	3.95	3.80	3.62	3.50	3.42	3.24	3.05	2.49	2.35	2.21	2.12	2.06	1.89
2HP14*24P	RBCS2M24C ****P+TXV	RBCS2M24C ****T	Btuh	27,400	25,900	24,400	22,800	21,800	21,100	19,600	18,100	17,700	16,300	15,000	14,200	13,700	12,300
			Kw	2.08	2.04	2.00	1.96	1.94	1.92	1.88	1.84	1.83	1.81	1.79	1.78	1.76	1.73
			COP	3.85	3.72	3.57	3.41	3.30	3.22	3.06	2.88	2.55	2.41	2.27	2.18	2.12	1.95
2HP14*30P	RBCS2M30C ****P+TXV	RBCS2M30C ****T ****P+TXV	Btuh	32,700	30,900	29,100	27,200	26,000	25,200	23,400	21,600	21,100	19,700	19,100	18,400	17,700	15,900
			Kw	2.40	2.35	2.30	2.25	2.22	2.19	2.14	2.09	2.07	2.01	1.94	1.92	1.87	1.85
			COP	3.98	3.85	3.71	3.55	3.44	3.36	3.20	3.02	2.62	2.49	2.35	2.26	2.20	2.03
2HP14*36P	RBCS2M36C ****P+TXV	RBCS2M36C ****T	Btuh	41,500	39,300	37,000	34,600	33,000	32,000	29,700	27,400	25,400	23,500	21,600	20,400	19,600	17,600
			Kw	3.08	3.01	2.95	2.88	2.84	2.82	2.75	2.69	2.67	2.66	2.59	2.55	2.53	2.46
			COP	3.95	3.82	3.67	3.51	3.40	3.32	3.16	2.98	2.73	2.58	2.44	2.34	2.27	2.10
2HP14*42P	RBCS2M42C ****P+TXV	RBCS2M42C ****T ****P+TXV	Btuh	48,400	45,800	43,100	40,300	38,500	37,300	34,700	32,000	29,700	27,400	25,200	23,800	22,900	20,600
			Kw	3.54	3.48	3.42	3.35	3.32	3.29	3.23	3.17	3.15	3.13	3.07	3.03	3.01	2.94
			COP	4.00	3.85	3.69	3.52	3.40	3.32	3.14	2.95	2.71	2.56	2.40	2.30	2.23	2.05
2HP14*48P	RBCS2M60C ****P+TXV	RBCS2M60C ****T	Btuh	57,200	54,100	51,000	47,600	45,500	44,100	41,000	37,800	34,100	31,500	29,000	27,400	26,400	23,700
			Kw	3.98	3.90	3.83	3.75	3.70	3.67	3.60	3.52	3.44	3.36	3.28	3.24	3.21	3.13
			COP	4.20	4.06	3.90	3.72	3.60	3.52	3.33	3.14	2.91	2.75	2.59	2.48	2.41	2.21
2HP14*48P	RBCS2M60V ****P+TXV	---	Btuh	66,000	62,500	58,800	55,000	52,500	50,900	47,300	43,600	39,900	36,800	33,900	32,000	30,800	27,600
			Kw	5.04	4.93	4.83	4.72	4.66	4.62	4.52	4.41	4.35	4.24	4.14	4.08	4.03	3.93
			COP	3.83	3.71	3.56	3.41	3.30	3.23	3.06	2.89	2.68	2.54	2.40	2.30	2.24	2.06

* = B, L

Accessories

Description	Where Used	Catalog #
Hard Start Kit	2HP14* 18, 24, 30, 36, 42, 48, 60	12W59
High Pressure Switch	2HP14* 18, 24, 30, 36, 42, 48, 60	14W09
Low Pressure Switch	Factory Installed on all Models	
Short Cycle Protection		
Crankcase Heater	2HP14* 18, 24, 30, 36, 42, 48, 60	14W05
Sound Blanket	2HP14* 18, 24, 30	14W02
	2HP14* 36, 42, 48, 60	14W00
Outdoor Thermostat	2HP14* 18, 24, 30, 36, 42, 48, 60	17W03
Fossil Fuel Kit	2HP14* 18, 24, 30, 36, 42, 48, 60	17W02
TXV	2HP14* 18, 24, 30, 36,	H2TXV01
	2HP14* 42, 48, 60	H2TXV02

* = B, L



Duconne™
**AIR CONDITIONING
 AND HEATING**

www.ducanehvac.com
 1-800-448-5872

All specifications and illustrations
 subject to change without notice
 and without incurring obligations.