

Split System Heat Pump

13
seer

4HP13 Features and Benefits

- High-quality condenser coil with copper tubing and enhanced louvered fin for maximum heat transfer capacity
- Top discharge directs hot air and sound away from living area and shrubbery
- All units run tested
- Available with louvered panel or wire guard coil protection option
- Easy access to electrical panels, pre-wired for easy hook-up
- Hinged control panel allows simple access to internal components
- Bi-directional liquid line filter drier factory installed
- Discharge muffler for quiet operation
- Reliable, solid state time/temperature defrost control, with field selectable 30/60/90 minute intervals
- Defrost control is Quiet Shift capable
- Low pressure switch factory installed for loss of charge protection
- Integrated control with LED diagnostics
- Short cycle protection factory installed
- All units ETL, ETL C approved and ARI listed
- Charged for 15 feet of interconnecting tubing
- 10 year limited parts warranty available



L Model



B Model

Model Number Guide

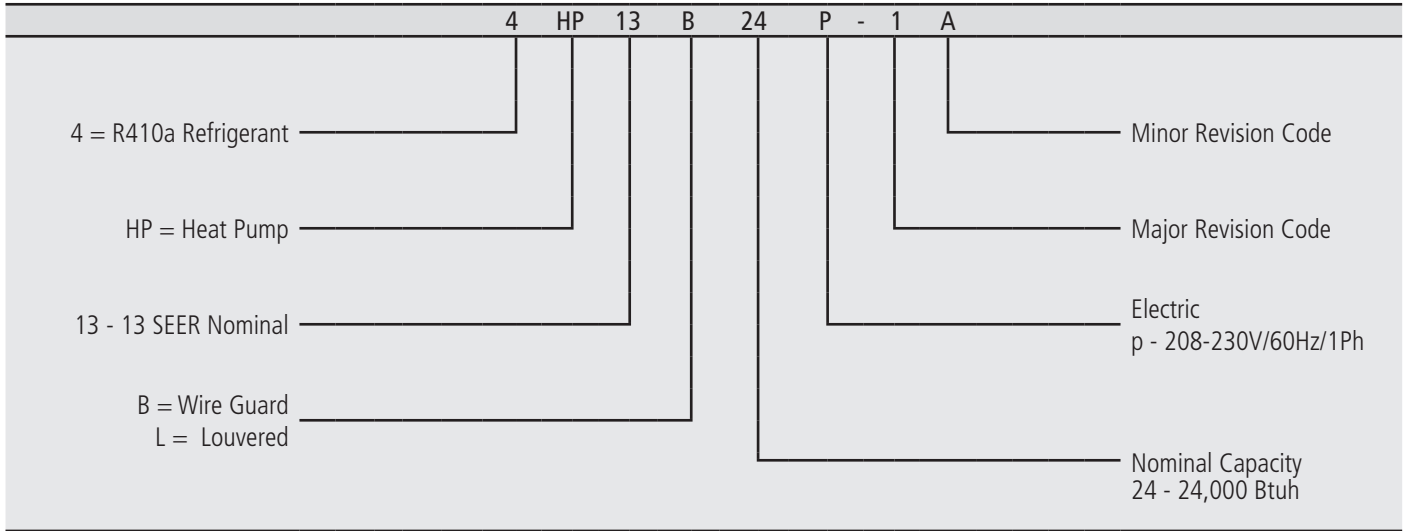

Physical and Electrical Data

Model	Volts/Hz/Phase	Voltage Range	Min. Circuit Amp.	Max. Over-current Device (amps)	Compressor		Fan Motor			Refrig. Charge (oz.)	Weight (lbs.)
					Rated Load (amps)	Locked Rotor (amps)	Rated Load (amps)	Rated HP	Nom. RPM		Wire Guard/Louvered
4HP13*18P	208-230/60/1	197/253	11.90	20	9.0	48	0.7	1/10	1075	117	151/166
4HP13*24P	208-230/60/1	197/253	11.10	15	8.3	43	0.7	1/10	1075	130	169/185
4HP13*30P	208-230/60/1	197/253	14.4	20	10.6	54	1.1	1/5	1075	159	186/203
4HP13*36P	208-230/60/1	197/253	19.6	30	14.7	74	1.2	1/4	1075	151	197/208
4HP13*42P	208-230/60/1	197/253	20.2	30	15.2	84	1.2	1/4	1075	170	218/229
4HP13*48P	208-230/60/1	197/253	25.1	35	19.1	102	1.2	1/4	1075	267	260/277
4HP13*60P	208-230/60/1	197/253	26.7	40	20.4	105	1.2	1/4	1075	251	262/279

* = B or L

Unit Dimensions & Sound Ratings

Model	Dimensions			Sound Ratings (dBA)
	A (in.)	B (in.)	C (in.)	
4HP13*18P	30	30	33.75	77
4HP13*24P	30	30	33.75	78
4HP13*30P	30	30	37.75	78
4HP13*36P	30	30	25.75	77
4HP13*42P	30	30	25.75	77
4HP13*48P	30	30	37.75	79
4HP13*60P	30	30	41.75	79

* = B or L

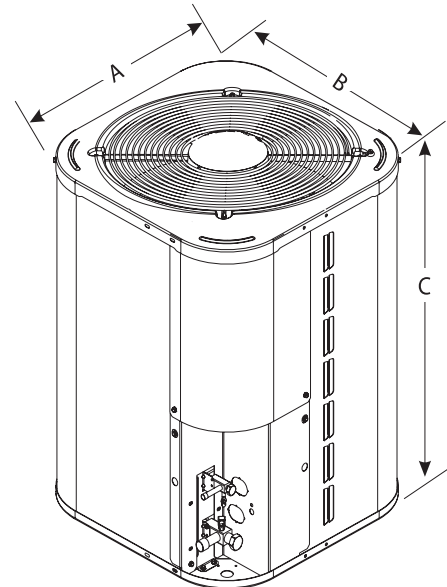

Cooling Performance with Air Handlers and Furnaces 18, 24, 30

Outdoor Model	Indoor Model	Furnace	Cooling				Heating						Refrigerant Connection		Refrigerant Line Size		Indoor Metering Device			
			SEER	EER	ARI Rated Capacity ¹	Rated Sensible Capacity	HSPF	47°		17°		CFM	Outdoor		Indoor		Suction	Liquid	Req'd	Optional
								Btuh	COP	Btuh	COP		Suction	Liquid	Suction	Liquid				
4HP13*18	E(C,H,M,U)1P36B+TXV	CG80*C***V12B	13.50	11.50	18,200	13,300	7.80	16,700	3.48	10,400	2.34	650	3/4	3/8	3/4	3/8	3/4	3/8	---	H4TXV01
	E(C,H,M,U)1P36B+TXV	CG95*C***V12B	13.50	11.50	18,200	13,300	7.80	16,700	3.48	10,400	2.34	650	3/4	3/8	3/4	3/8	3/4	3/8	---	H4TXV01
	RBCS2M18C****P	----	13.00	11.00	18,000	13,100	7.70	16,800	3.30	10,500	2.18	650	3/4	3/8	3/4	3/8	3/4	3/8	0.051	H4TXV01
	RBCS2M18C****P+TXV	----	13.00	11.00	18,000	13,100	7.70	16,800	3.30	10,500	2.18	650	3/4	3/8	3/4	3/8	3/4	3/8	---	H4TXV01
	RBCS2M24V****P	----	14.00	12.00	18,300	13,300	7.90	16,500	3.52	10,200	2.34	650	3/4	3/8	3/4	3/8	3/4	3/8	0.051	H4TXV01
	RBCS2M24V****P	----	14.00	12.00	18,300	13,300	7.90	16,500	3.52	10,200	2.34	650	3/4	3/8	3/4	3/8	3/4	3/8	---	H4TXV01
4HP13*24	E(C,H,M,U)1P36B+TXV	CG80*C***V12B	13.00	11.00	24,400	18,600	7.70	23,400	3.72	11,900	2.34	900	3/4	3/8	3/4	3/8	3/4	3/8	---	H4TXV01
	E(C,H,M,U)1P36B+TXV	CG80*C***V14B	13.00	11.00	24,400	18,600	7.70	23,400	3.72	11,900	2.34	900	3/4	3/8	3/4	3/8	3/4	3/8	---	H4TXV01
	E(C,H,M,U)1P36B+TXV	CG95*C***V12B	13.00	11.00	24,400	18,600	7.70	23,400	3.72	11,900	2.34	900	3/4	3/8	3/4	3/8	3/4	3/8	---	H4TXV01
	E(C,H,M,U)1P36B+TXV	CG95*C***V14B	13.00	11.00	24,400	18,600	7.70	23,400	3.72	11,900	2.34	900	3/4	3/8	3/4	3/8	3/4	3/8	---	H4TXV01
	RBCS2M24C****P	----	13.00	11.00	24,000	18,200	7.70	21,400	3.34	11,800	2.18	900	3/4	3/8	3/4	3/8	3/4	3/8	0.055	H4TXV01
	RBCS2M24C****P+TXV	----	13.00	11.00	24,000	18,200	7.70	21,400	3.34	11,800	2.18	900	3/4	3/8	3/4	3/8	3/4	3/8	---	H4TXV01
	RBCS2M24V****P	----	14.00	12.00	24,000	18,400	7.90	20,800	3.60	11,400	2.44	900	3/4	3/8	3/4	3/8	3/4	3/8	0.055	H4TXV01
	RBCS2M24V****P+TXV	----	14.00	12.00	24,200	18,400	7.90	20,800	3.60	11,400	2.44	900	3/4	3/8	3/4	3/8	3/4	3/8	---	H4TXV01
4HP13*30	E(C,H,M,U)1P36B+TXV	CG80*C***V12B	13.00	11.00	28,000	20,700	7.70	27,000	3.40	15,400	2.46	1050	3/4	3/8	3/4	3/8	3/4	3/8	---	H4TXV01
	E(C,H,M,U)1P36B+TXV	CG80*C***V14B	13.00	11.00	28,000	20,700	7.70	27,000	3.40	15,400	2.46	1050	3/4	3/8	3/4	3/8	3/4	3/8	---	H4TXV01
	E(C,H,M,U)1P36B+TXV	CG95*C***V12B	13.00	11.00	28,000	20,700	7.70	27,000	3.40	15,400	2.46	1050	3/4	3/8	3/4	3/8	3/4	3/8	---	H4TXV01
	E(C,H,M,U)1P36B+TXV	CG95*C***V14B	13.00	11.00	28,000	20,700	7.70	27,000	3.40	15,400	2.46	1050	3/4	3/8	3/4	3/8	3/4	3/8	---	H4TXV01
	RBCS2M30C****P	----	13.00	11.00	28,000	20,700	7.70	27,000	3.34	15,400	2.26	1050	3/4	3/8	3/4	3/8	3/4	3/8	0.059	H4TXV01
	RBCS2M30C****P+TXV	----	13.00	11.00	28,000	20,700	7.70	27,000	3.34	15,400	2.26	1050	3/4	3/8	3/4	3/8	3/4	3/8	---	H4TXV01
	RBCS2M36V****P	----	14.00	11.50	28,200	20,900	7.90	26,600	3.58	14,800	2.56	1050	3/4	3/8	3/4	3/8	3/4	3/8	0.059	H4TXV01
	RBCS2M36V****P+TXV	----	14.00	11.50	28,200	20,900	7.90	26,600	3.58	14,800	2.56	1050	3/4	3/8	3/4	3/8	3/4	3/8	---	H4TXV01

* = B or L

¹ Certified in accordance with Unitary Air Conditioner Certification Program, which is based on ARI Standard 210/240

Cooling Performance with Air Handlers and Furnaces 36, 42, 48, 60

Outdoor Model	Indoor Model	Furnace	Cooling				Heating						Refrigerant Connection				Refrigerant Line Size		Indoor Metering Device	
			SEER	EER	ARI Rated Capacity ¹	Rated Sensible Capacity	HSPF	47°		17°		CFM	Outdoor		Indoor		Suction	Liquid	Req'd	Optional
								Btuh	COP	Btuh	COP		Suction	Liquid	Suction	Liquid				
4HP13*36	E(C,H,M,U)1P36B+TXV	CG80*C***V12B	13.00	11.00	35,400	26,900	7.70	33,000	3.48	19,100	2.48	1250	3/4	3/8	3/4	3/8	3/4	3/8	---	H4TXV02
	E(C,H,M,U)1P36B+TXV	CG80*C***V14B	13.00	11.00	35,400	26,900	7.70	33,000	3.48	19,100	2.48	1250	3/4	3/8	3/4	3/8	3/4	3/8	---	H4TXV02
	E(C,H,M,U)1P36B+TXV	CG95*C***V12B	13.00	11.00	35,400	26,900	7.70	33,000	3.48	19,100	2.48	1250	3/4	3/8	3/4	3/8	3/4	3/8	---	H4TXV02
	E(C,H,M,U)1P36B+TXV	CG95*C***V14B	13.00	11.00	35,400	26,900	7.70	33,000	3.48	19,100	2.48	1250	3/4	3/8	3/4	3/8	3/4	3/8	---	H4TXV02
	E(C,H,M,U)1P43B+TXV	CG80*C***V12B	13.00	11.00	35,800	27,200	7.70	34,800	3.62	19,100	2.48	1250	3/4	3/8	7/8	3/8	3/4	3/8	---	H4TXV02
	E(C,H,M,U)1P43B+TXV	CG80*C***V14B	13.00	11.00	35,800	27,200	7.70	34,800	3.62	19,100	2.48	1250	3/4	3/8	7/8	3/8	3/4	3/8	---	H4TXV02
	E(C,H,M,U)1P43B+TXV	CG95*C***V12B	13.00	11.00	35,800	27,200	7.70	34,800	3.62	19,100	2.48	1250	3/4	3/8	7/8	3/8	3/4	3/8	---	H4TXV02
	E(C,H,M,U)1P43B+TXV	CG95*C***V14B	13.00	11.00	35,800	27,200	7.70	34,800	3.62	19,100	2.48	1250	3/4	3/8	7/8	3/8	3/4	3/8	---	H4TXV02
	RBCS2M36C****P	----	13.00	11.00	35,600	27,000	7.70	33,000	3.40	19,000	2.26	1250	3/4	3/8	3/4	3/8	3/4	3/8	0.070	H4TXV02
	RBCS2M36C****P+TXV	----	13.00	11.00	35,600	27,000	7.70	33,000	3.40	19,000	2.26	1250	3/4	3/8	3/4	3/8	3/4	3/8	---	H4TXV02
RBCS2M36V****P	----	14.00	11.50	36,000	27,400	7.80	32,400	3.62	18,400	2.60	1250	3/4	3/8	3/4	3/8	3/4	3/8	0.070	H4TXV02	
RBCS2M36V****P+TXV	----	14.00	11.50	36,000	27,400	7.80	32,400	3.62	18,400	2.60	1250	3/4	3/8	3/4	3/8	3/4	3/8	---	H4TXV02	
4HP13*42	E(C,H,U)1P62C+TXV	CG80*C***V20C	13.50	11.50	43,000	30,900	7.70	39,000	3.50	21,600	2.38	1350	7/8	3/8	7/8	3/8	7/8	3/8	---	H4TXV02
	RBCS2M42C****P	----	13.00	11.00	42,000	30,200	7.70	38,500	3.42	21,200	2.24	1350	7/8	3/8	7/8	3/8	7/8	3/8	0.070	H4TXV02
	RBCS2M42C****P+TXV	----	13.00	11.00	42,000	30,200	7.70	38,500	3.42	21,200	2.24	1350	7/8	3/8	7/8	3/8	7/8	3/8	---	H4TXV02
	RBCS2M42V****P	----	14.00	12.00	42,500	30,600	7.80	38,000	3.52	20,600	2.62	1350	7/8	3/8	7/8	3/8	7/8	3/8	0.070	H4TXV02
	RBCS2M42V****P+TXV	----	14.00	12.00	42,500	30,600	7.80	38,000	3.52	20,600	2.62	1350	7/8	3/8	7/8	3/8	7/8	3/8	0.070	H4TXV02
4HP13*48	E(C,M,U)1P62C+TXV	CG80*C***V20C	13.00	11.50	48,500	35,900	7.70	43,500	3.24	27,200	2.38	1600	7/8	3/8	7/8	3/8	7/8	3/8	---	H4TXV03
	RBCS2M48C****P	----	13.00	11.00	48,000	35,500	7.70	43,500	3.20	27,400	2.50	1600	7/8	3/8	7/8	3/8	7/8	3/8	0.082	H4TXV03
	RBCS2M48C****P+TXV	----	13.00	11.00	48,000	35,500	7.70	43,500	3.20	27,400	2.50	1600	7/8	3/8	7/8	3/8	7/8	3/8	---	H4TXV03
	RBCS2M48V****P	----	14.00	11.50	48,500	35,900	8.00	43,000	3.28	27,000	2.58	1600	7/8	3/8	7/8	3/8	7/8	3/8	0.082	H4TXV03
	RBCS2M48V****P+TXV	----	14.00	11.50	48,500	35,900	8.00	43,000	3.28	27,000	2.58	1600	7/8	3/8	7/8	3/8	7/8	3/8	---	H4TXV03
4HP13*60	RBCS2M60C****P	----	13.00	11.00	54,500	40,900	7.70	52,000	3.74	30,400	2.58	1800	7/8	3/8	7/8	3/8	1-1/8	3/8	0.082	H4TXV03
	RBCS2M60C****P+TXV	----	13.00	11.00	54,500	40,900	7.70	52,000	3.74	30,400	2.58	1800	7/8	3/8	7/8	3/8	1-1/8	3/8	---	H4TXV03
	RBCS2M60V****P	----	13.50	11.50	54,500	40,900	8.00	51,500	3.80	30,000	2.64	1800	7/8	3/8	7/8	3/8	1-1/8	3/8	0.082	H4TXV03

* = B or L

¹ Certified in accordance with Unitary Air Conditioner Certification Program, which is based on ARI Standard 210/240

Cooling Performance with Extended Ratings

Outdoor Model	Indoor Model	Indoor Temp DB/WB °F	Outdoor Temp - DB°F														
			65			82			95			105			115		
			Btuh	S/T	kW	Btuh	S/T	kW	Btuh	S/T	kW	Btuh	S/T	kW	Btuh	S/T	kW
4HP13*18P	RBCS2M18	85/72	20,000	0.59	1.24	19,500	0.64	1.46	19,100	0.68	1.64	18,000	0.71	1.83	16,900	0.74	2.03
		80/67	18,800	0.67	1.23	19,100	0.71	1.44	18,000	0.76	1.64	16,300	0.80	1.83	14,700	0.84	2.01
		75/63	18,200	0.72	1.23	17,100	0.77	1.45	16,300	0.80	1.63	15,000	0.84	1.82	13,700	0.88	2.01
		75/57	16,400	1.00	1.21	17,000	1.00	1.41	16,000	1.00	1.61	14,500	1.00	1.79	13,100	1.00	1.97
4HP13*24P	RBCS2M24	85/72	27,700	0.59	1.75	26,600	0.63	2.01	25,800	0.66	2.21	23,400	0.71	2.35	21,000	0.76	2.50
		80/67	26,600	0.66	1.74	25,700	0.70	1.98	24,000	0.74	2.18	21,100	0.80	2.30	18,300	0.86	2.41
		75/63	25,200	0.70	1.73	22,600	0.76	1.95	20,600	0.80	2.12	18,400	0.85	2.24	16,100	0.90	2.36
		75/57	23,100	1.00	1.71	22,900	1.00	1.94	21,400	1.00	2.14	18,800	1.00	2.25	16,300	1.00	2.36
4HP13*30P	RBCS2M30	85/72	33,500	0.60	2.05	31,900	0.65	2.37	30,700	0.68	2.61	28,000	0.73	2.78	25,400	0.77	2.95
		80/67	31,800	0.67	2.03	30,900	0.72	2.33	28,000	0.77	2.55	24,900	0.83	2.69	21,700	0.88	2.83
		75/63	30,200	0.72	2.02	27,300	0.77	2.28	25,000	0.81	2.48	22,400	0.85	2.62	19,800	0.89	2.76
		75/57	27,700	1.00	1.99	27,500	1.00	2.28	24,900	1.00	2.50	22,200	1.00	2.64	19,300	1.00	2.77
4HP13*36P	RBCS2M36	85/72	40,500	0.59	2.48	39,400	0.63	2.92	38,500	0.66	3.26	35,100	0.71	3.50	31,600	0.75	3.75
		80/67	38,900	0.66	2.48	39,700	0.69	2.93	35,600	0.75	3.24	31,000	0.81	3.44	26,400	0.87	3.65
		75/63	37,600	0.69	2.49	33,800	0.75	2.87	30,800	0.80	3.16	27,500	0.85	3.37	24,100	0.90	3.57
		75/57	33,800	1.00	2.43	35,300	1.00	2.87	31,700	1.00	3.18	27,600	1.00	3.37	23,500	1.00	3.58
4HP13*42P	RBCS2M42	85/72	51,700	0.57	3.02	49,500	0.61	3.52	47,800	0.64	3.90	43,400	0.68	4.16	39,100	0.71	4.43
		80/67	49,400	0.64	3.01	45,800	0.69	3.48	42,000	0.73	3.82	38,200	0.77	4.04	34,400	0.80	4.26
		75/63	47,100	0.67	2.98	42,500	0.69	3.40	39,100	0.71	3.73	34,800	0.78	3.94	30,400	0.84	4.16
		75/57	43,000	1.00	2.95	40,800	1.00	3.41	37,400	1.00	3.74	34,000	1.00	3.96	30,600	1.00	4.17
4HP13*48P	RBCS2M48	85/72	57,400	0.62	3.42	55,400	0.64	4.00	53,900	0.66	4.44	48,800	0.70	4.76	43,700	0.73	5.07
		80/67	55,300	0.67	3.39	53,100	0.70	3.96	48,000	0.74	4.36	43,000	0.79	4.65	38,100	0.84	4.94
		75/63	53,000	0.71	3.37	47,600	0.75	3.89	43,500	0.78	4.28	39,300	0.83	4.55	35,100	0.87	4.82
		75/57	48,100	1.00	3.32	47,300	1.00	3.88	42,700	1.00	4.27	38,300	1.00	4.56	33,900	1.00	4.84
4HP13*60P	RBCS2M60	85/72	62,700	0.59	3.86	61,000	0.63	4.55	59,800	0.66	5.08	55,000	0.70	5.44	50,200	0.74	5.80
		80/67	61,200	0.67	3.85	59,900	0.70	4.51	54,500	0.75	4.95	48,800	0.80	5.26	43,100	0.85	5.58
		75/63	59,100	0.71	3.84	53,200	0.76	4.43	48,700	0.80	4.88	43,700	0.84	5.14	38,600	0.88	5.41
		75/57	53,200	1.00	3.77	53,300	1.00	4.42	48,500	1.00	4.85	43,400	1.00	5.15	38,400	1.00	5.47

* = B, L

Note: Extended data shown is actual for models listed and typical for all AHRI matches.

Heating Performance with Extended Ratings

The information below is for nominal CFM and 70° indoor dry bulb.

Outdoor Model	Indoor Model	Outdoor Ambient Temperature														
			65	60	55	50	47	45	40	35	30	25	20	17	15	10
4HP13*18P	RBCS2M18C *****p	Btuh	21,500	20,200	18,700	17,500	16,800	16,300	15,400	14,300	13,100	12,300	10,900	10,500	9,800	8,700
		Kw	1.58	1.55	1.53	1.50	1.49	1.480	1.47	1.46	1.44	1.43	1.42	1.41	1.40	1.39
		COP	3.98	3.82	3.58	3.42	3.30	3.22	3.06	2.86	2.66	2.52	2.24	2.18	2.04	1.84
4HP13*24P	RBCS2M24C *****p	Btuh	24,100	23,500	22,800	22,000	21,400	20,800	19,200	17600	16200	14700	13000	11800	11200	9200
		Kw	1.94	1.92	1.90	1.88	1.87	1.84	1.76	1.73	1.69	1.66	1.62	1.60	1.59	1.55
		COP	3.64	3.59	3.52	3.44	3.34	3.32	3.20	2.98	2.80	2.60	2.34	2.18	2.06	1.74
4HP13*30P	RBCS2M30C *****p	Btuh	30,200	29,500	28,500	27,600	27,000	25,700	23,500	22,300	20,600	18,400	16,500	15,400	14,700	12,100
		Kw	2.47	2.43	2.40	2.38	2.37	2.31	2.25	2.21	2.16	2.11	2.30	2.04	2.00	1.93
		COP	3.58	3.56	3.48	3.40	3.34	3.26	3.06	2.96	2.80	2.56	2.38	2.26	2.14	1.84
4HP13*36P	RBCS2M36C *****p	Btuh	37,600	36,300	35,200	34,000	33,000	31,300	29,300	27,500	25,300	22,800	20,500	19,000	17,900	15,100
		Kw	3.03	2.95	2.90	2.87	2.85	2.76	2.70	2.64	2.59	2.54	2.49	2.45	2.45	2.41
		COP	3.64	3.60	3.56	3.46	3.40	3.32	3.18	3.04	2.86	2.62	2.40	2.26	2.14	1.84
4HP13*42P	RBCS2M42C *****p	Btuh	43,500	42,400	41,000	39,200	38,500	36,100	32,800	30,900	28,300	25,200	22,400	21,200	18,700	13,300
		Kw	3.54	3.47	3.41	3.32	3.30	3.23	3.11	3.04	2.88	2.70	2.49	2.39	2.28	2.00
		COP	3.60	3.58	3.52	3.46	3.42	3.28	3.08	2.98	2.88	2.74	2.64	2.60	2.40	1.94
4HP13*48P	RBCS2M60C *****p	Btuh	51,800	49,100	46,200	44,200	43,500	41,900	41,300	37,400	34,900	32,500	29,700	27,400	26,600	24,200
		Kw	4.56	4.35	4.14	4.00	3.98	3.87	3.83	3.64	3.52	3.44	3.31	3.23	3.22	3.13
		COP	3.32	3.30	3.26	3.24	3.20	3.18	3.16	3.00	2.90	2.76	2.62	2.50	2.42	2.26
4HP13*60P	RBCS2M60C *****p	Btuh	58,700	56,300	54,200	52,900	52,000	49,600	46,600	42,400	39,300	36,100	32,600	30,400	29,000	25,500
		Kw	4.34	4.19	4.14	4.10	4.07	4.03	3.96	3.82	3.72	3.63	3.53	3.46	3.41	3.31
		COP	3.96	3.94	3.84	3.78	3.74	3.60	3.44	3.24	3.10	2.92	2.70	2.58	2.48	2.26

* = B, L

Accessories

Description	Where Used	Kit Number
Compressor Sound Cover	4HP13*18	14W00
Compressor Sound Cover	4HP13*24, 30, 36	47W03
Compressor Sound Cover	4HP13*42, 48, 60	47W04
Crankcase Heater	4HP13*18	14W05
Hard Start Kit	4HP13*18	12W59
Hard Start Kit	4HP13*24	47W10
Hard Start Kit	4HP13*30	47W09
Hard Start Kit	4HP13*36	47W08
Hard Start Kit	4HP13*42, 48	47W06
Hard Start Kit	4HP13*60	47W05
TXV Kit ¹	4HP13*18, 24,30	H4TXV01
TXV Kit ¹	4HP13*36,42	H4TXV02
TXV Kit ¹	4HP13*48,60	H4TXV03
Blower Off Delay Kit	All Units	40K58
Low Ambient Kit	All Units	34M72
Liquid Line Solenoid	All Units	20443001

* = B, L

¹ Note: When using indoor TXV Kits with 4HP13B/L 24, 30, 36, 42, 48, 60 models, the appropriate hard start kit above must also be installed for proper performance.

13
seer

4HP13 Split System Heat Pump

Ducane™ AIR CONDITIONING AND HEATING

www.ducanehvac.com
1-800-448-5872



All specifications and illustrations
subject to change without notice
and without incurring obligations.